



VGD20...



VGD40.../VGD41...

Double gas valves

**VGD2...
VGD4...**

- Double gas valves of class A for integration into gas trains
- Safety shutoff valves conforming to EN 161 in connection with SKPx5... actuators
- Suited for use with gases of gas families I...III
- Double gas valves in connection with SKPx5... actuators open slowly and close rapidly
- 2-port valves of the normally closed type
- Sizes 1 ½" ... DN 150
- The double gas valves are designed for combination with 2 actuators
- Supplementary Data Sheets on actuators: See *Mechanical design*

The VGD2.../VGD4... and this Data Sheet are intended for use by OEMs which integrate the double gas valves in their products!

Use

The double gas valves are used primarily:

- On gas-fired combustion plant
- In gas trains in connection with forced draft gas burners

They serve as:

- Shutoff valves (in connection with SKP15... actuators)
- Control valves with shutoff feature (in connection with SKP25..., SKP55... or SKP75... actuators)

All types of double gas valves can be combined with any type of SKPx5... actuator.

Warning notes



To avoid injury to persons, damage to property or the environment, the following warning notes must be observed!

Do not open, interfere with or modify the double gas valves!

Any opening of the valve, replacement of parts or modifications to the original product is the user's responsibility and is done at his own risk.

- All activities (mounting, installation and service work, etc.) must be carried out by qualified staff
- Fall or shock can adversely affect the safety functions. Such valves must not be put into operation, even if they do not exhibit any damage
- In combination with SAX31... actuators, the gas valves must **not** be used as safety devices

Mounting notes

- Ensure that the relevant national safety regulations are complied with
- The actuator can be fitted or replaced while the valve is under gas pressure
- Also observe the following Mounting Instructions:

VGD...	M7631/M7636	4 319 2072 0
VGD2...	M7631	4 319 2343 0
VGD40.../VGD40...L/VGD41... for DN 40...150	M7631.2	74 319 0244 0
VGD40... for North America	M7631.3	74 319 0278 0
AGA40...51	M7631.1	4 319 2142 0
AGA66	M7643.2	74 319 0421 0

- With SKP25...: Impulse pipe (pressure feedback) on double valve possible
- With SKP75...: Impulse pipe (pressure feedback) must be connected to the gas pipe, downstream from the valve, observing a distance of at least 3...5 D

Gasket/tightness

- Check to ensure that the bolts on the flanges are properly tightened; then make certain that the connections with all components are tight
- The O-rings or flange gaskets must be fitted between the flanges and the double valve

Mounting position

The permissible mounting positions of the actuators must be observed (refer to the relevant Data Sheets).

Direction of flow

The direction of gas flow must be in accordance with the direction of the arrow on the valve body.

Function

The double gas valve is normally closed and opened when the SKPx5... actuator opens.

VGD20...

- Mount the electrohydraulic SKP15... actuator on the valve's inlet side and the actuator with integrated gas pressure governor (SKP25..., SKP55... or SKP75...) on the valve's outlet side
- When mounting the double gas valve in the gas train, 2 AGA41.../AGA51... flanges are required
- To prevent cuttings from falling inside the valve, first fit the flanges to the piping and then clean the respective parts

Standards and certificates



Conformity to EU directives

- Electromagnetic compatibility EMC (immunity)
- Directive for gas-fired appliances
- Directive for pressure devices

2004/108/EC

2009/142/EC

97/23/EC



ISO 9001: 2010

Cert. 00739



ISO 14001: 2010

Cert. 38233

For use in the U.S./Canada, the double gas valves carry type suffix **U** (see example) and are , and listed.

Example: VGD20.403**U**

Approvals in connection
with SKPx5... actuator

Type			
VGD20.403	●	●	●
VGD20.503	●	●	●
VGD20.4011	●	●	●
VGD20.5011	●	●	●
VGD40.040	●	●	●
VGD40.050	●	●	●
VGD40.065	●	●	●
VGD40.080	●	●	●
VGD40.100	●	●	●
VGD40.125	●	●	●
VGD40.150	●	●	●
VGD40.040L	●	●	---
VGD40.050L	●	●	---
VGD40.065L	●	●	---
VGD40.080L	●	●	---
VGD40.100L	●	●	---
VGD40.125L	●	●	---
VGD40.150L	●	●	---
VGD41.040	---	●	---
VGD41.050	---	●	---
VGD41.065	---	●	---
VGD41.080	---	●	---
VGD41.100	---	●	---
VGD41.125	---	●	---
VGD41.150	---	●	---

Life cycle

The combination gas valve VG... and actuator have a designed lifetime* of

Nominal sizes	Burner startup cycles
≤25 DN	200.000
25...80 DN	100.000
80...150 DN	50.000

under use of gases to EN 437 (or DVGW specification G260). This lifetime is based on the endurance tests specified in standard EN 161 and the table containing the relevant test documentation as published by the European Association of Component Manufacturers (Afecor) (www.afecor.org).

The designed lifetime is based on use of the gas valve VG... and actuator according to the manufacturer's Data Sheet. After reaching the designed lifetime in terms of the number of burner startup cycles, or the respective time of usage, the gas valve VG... and actuator are to be replaced by authorized personnel.

* The designed lifetime is not the warranty time specified in the Terms of Delivery

Service notes

- Each time a double gas valve has been replaced, check the correct functioning and the internal and external tightness of the valve
- The double gas valves supplied by Siemens may **only** be repaired by Siemens AG Repair Centers

Disposal notes



Local and currently valid legislation must be observed.

Mechanical design

Strainer

A strainer made of stainless steel is fitted near the valve's inlet to protect the valve, the seat and the disk as well as downstream devices against dirt.

AGA41/AGA51 connecting flanges for VGD20...

The connecting flanges have a ¼" test point. They are internally threaded and supplied as separate items together with the necessary accessories, such as bolts, nuts, and gaskets. A 1 ½" flange can also be used with a 2" double valve, and vice versa. Each double gas valve requires 2 connecting flanges.

VGD20...

Sectional view of VGD20...

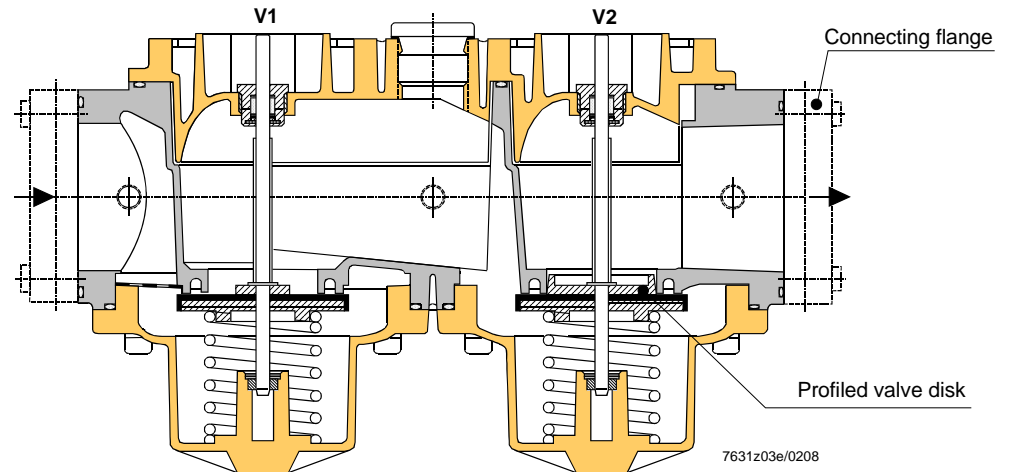

Application example

VGD20... with SKP15... (mounted on V1) and SKP75... (mounted on V2)

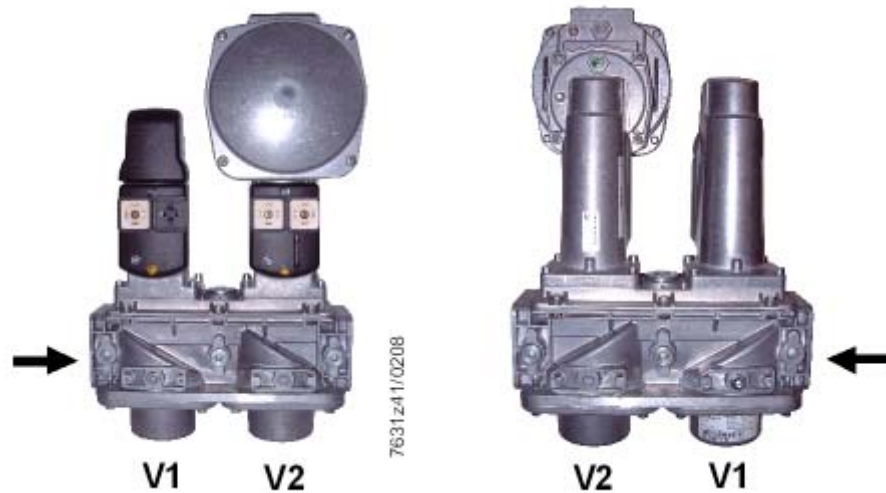

Mechanical design (cont'd)

VGD4... The VGD4... double gas valves are double-seat disk valves. The 1/4" impulse connection at the pilot gas flange, or the impulse connection at the outlet of valve **V1** or **V2**, can be connected to the impulse connection of the mounted constant pressure governor SKP25...

Closing springs Each double seat uses one pair of springs. The spring forces act separately as closing forces on the individual valve seats.

Pressure switch plate Pressure switch plate ① facilitates attachment of a number of commercially available pressure switches or valve proving devices. Pilot gas flange ② and pressure switch plate can be fitted on either side of the valve.

VGD4... Sectional view of VGD4...

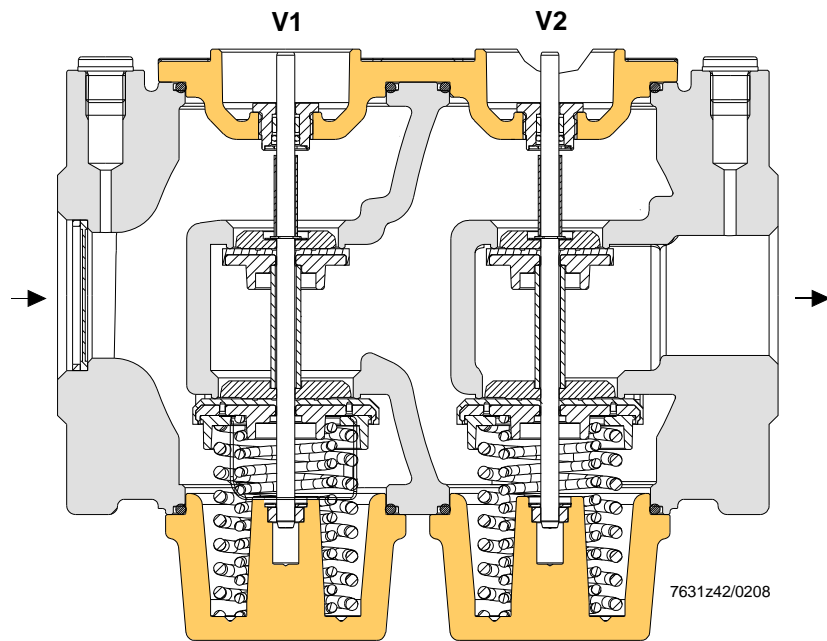

Application example VGD40.080 with SKP15... (mounted on valve **V1**) and SKP25... (mounted on valve **V2**).

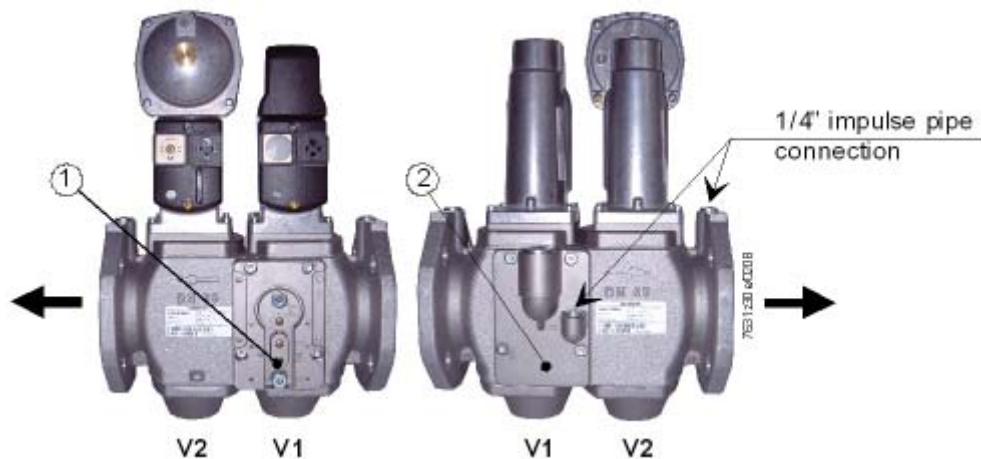

Mechanical design (cont'd)

Actuators

The double gas valves can be combined with the following types of actuators:

Product no.	Data Sheet	Function
SKP15...	N7643	ON/OFF
SKP25...	N7643	ON/OFF with constant pressure control/zero pressure control
SKP25.7... with SQS37...	N7643	ON/OFF with pressure control, predefined setpoint adjustable via electrical signal
SKP55...	N7643	ON/OFF with differential pressure control, signal input → differential pressure
SKP75...	N7643	ON/OFF with fuel / air ratio control, signal input → static pressure
SAX31... with AGA60	N4501	Modulating 3-position control, no safety shutoff function

Type summary (other types of valves on request)

VGD2...	Flow rate at $\Delta p = 10 \text{ mbar m}^3/\text{h air } ^1)$	Product no.	
		With 3 internally threaded connections	With 11 internally threaded connections
1 1/2"	85	VGD20.403	VGD20.4011
2"	100	VGD20.503	VGD20.5011

VGD4...	DN	Flow rate at $\Delta p = 10 \text{ mbar m}^3/\text{h air } ^1)$	Product no.	
			²⁾	³⁾
	40	85	VGD40.040	VGD41.040
	50	100	VGD40.050	VGD41.050
	65	160	VGD40.065	VGD41.065
	80	250	VGD40.080	VGD41.080
	100	400	VGD40.100	VGD41.100
	125	630	VGD40.125	VGD41.125
	150	800	VGD40.150	VGD41.150

- 1) Flow rate conforming to EN 161
- 2) VGD40...L with inverted position of mounting plates (see *Dimensions*)
- 3) VGD41... with pressure switch plate on both sides (see *Dimensions*)

Ordering

When ordering, please give product no. of the double gas valve.

Actuators, double gas valve and flanges (only VGD20...) are supplied as single packs.

Example: VGD20...

Double gas valve 2" complete with 2 connecting flanges

- 1 VGD20.503
- 2 actuators SKPx5...
- 2 AGA51

Example: VGD4...

Double gas valve DN 80

- 1 VGD40.080
- 2 actuators SKPx5...

The lateral mounting plates (pilot gas connection and pressure switch plate) are included in the scope of delivery and ready fitted.

Accessories

Connecting flanges for
VGD20.../VGD40...

Product no. of valve ¹⁾	Nominal size	Product no. of connecting flange
VGD20.403	1 ½"	AGA41
VGD20.503	2"	AGA51
VGD20.4011	1 ½"	AGA41
VGD20.5011	2"	AGA51

¹⁾ Internally threaded to ISO 7/1

Pressure switch connecting plate for VGD40...

AGA40.41

- Spare part (kit incl. grommet and gaskets)

Pilot gas connecting plate for VGD40...

AGA40.40

- Spare part (kit incl. grommet and gaskets)

Refer to Mounting Instruction M7631.1 (4 319 2142 0)!



Manually operated

AGA61



Adapter for SAX31... actuators

AGA60

Consisting of 2 stem items and 1 connecting flange



Gasket set for SKPx5.../SKL25...

AGA66

- Between SKPx5.../SKL25... actuator and VG... valve
- For improving the degree of protection from IP54 to IP65
- Refer to Mounting Instructions M7643.2 (74 319 0421 0)

Technical data

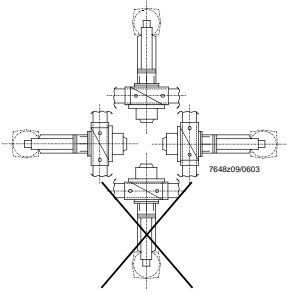
General valve data	Valve class (in connection with actuator)	A conforming to EN 161 (except with SAX31...)	
	Group	2 (EN 161)	
	Perm. medium temperature	-15...60 °C	
	Weight		
	- VGD20...	Approx. 3.2 kg	
	- VGD40...	See <i>Dimensions</i>	
	Connecting flanges for VGD40...	PN 16 to ISO 7005-2	
	Required flow rate	See <i>Flow chart</i>	
	Mounting position		
			
		See <i>Mounting notes</i>	
	Operating pressure	See <i>Type summary</i>	
	Types of gas	See <i>Use</i>	
	- VGD2...	Suited for use with gases of gas families I...III and air	
- VGD4...	No nonferrous materials Suited for use with gases up to max. max. 0,1 vol. % H ₂ S, dry		
Strainer	Built in (mesh size 0.9 mm)		
Materials	AlSi10Mg to DIN 1706		
Environmental conditions	Storage	DIN EN 60721-3-1	
	Climatic conditions	Class 1K3	
	Mechanical conditions	Class 1M2	
	Temperature range	-20...60 °C	
	Humidity	<95% r.h.	
	Transport	DIN EN 60721-3-2	
	Climatic conditions	Class 2K2	
	Mechanical conditions	Class 2M2	
	Temperature range	-15...60 °C	
	Humidity	<95% r.h.	
	Operation	DIN EN 60721-3-3	
	Climatic conditions	Class 3K5	
	Mechanical conditions	Class 3M2	
	Temperature range	-10...60 °C	
Humidity	<95% r.h.		

Technical data (cont'd)

Permissible gas pressures/volumes

Product no.	Static pressure (perm. inlet pressure with double gas valve fully closed) (mbar)	Dynamic pressure (perm. operating pressure) (mbar)	Volume between V1/V2 (liters)
VG20.403	600	600 (1400)*	0.75
VG20.503	600	600 (1400)*	0.8
VG20.4011	600	600 (1400)*	0.75
VG20.5011	600	600 (1400)*	0.8
VG40.040	1500	1000 (700)*	0.8
VG40.050	1500	1000 (700)*	0.8
VG40.065	1500	700	1.3
VG40.080	1500	700	1.5
VG40.100	1500	700	3
VG40.125	1500	700	5.2
VG40.150	1500	700	8.7

* Only for use in Australia

VG40...

The double gas valves are designed to withstand gas pressures up to 1,500 mbar in burner standby mode. At a pressure of 1,500 mbar, the double valve remains safely shut or will safely close when shutdown is initiated by an upstream pressure signal. Proper functioning and outer tightness are not affected.

Note:

Owing to the internal design of the double valves, increasing inlet pressure causes the valve to close (class A conforming to EN 161). This means that safety shutoff or venting devices that – in addition to the high-pressure regulator – are normally used for protecting the gas valve on the burner are no longer required if the following conditions are satisfied: If, in the event the high-pressure regulator upstream of the valve fails, 1,500 mbar at the inlet of the double valve are not exceeded and, in the event the permissible pressure of the double valve is exceeded (DN 65...150: 700 mbar or DN 40...50: 1,000 mbar), a shutoff device (e.g. gas pressure switch) causes the double valve to close.

Example: Possibilities of fitting the pressure switch with O-ring to the VGD20.4011 or VGD20.5011

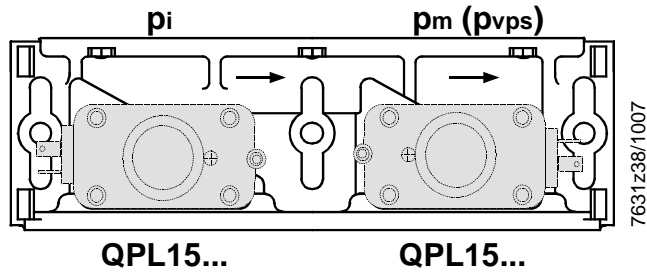

Example: Possibilities of fitting the pressure switch with nipple Rp1/4" to the VGD20.403... or VGD20.503...

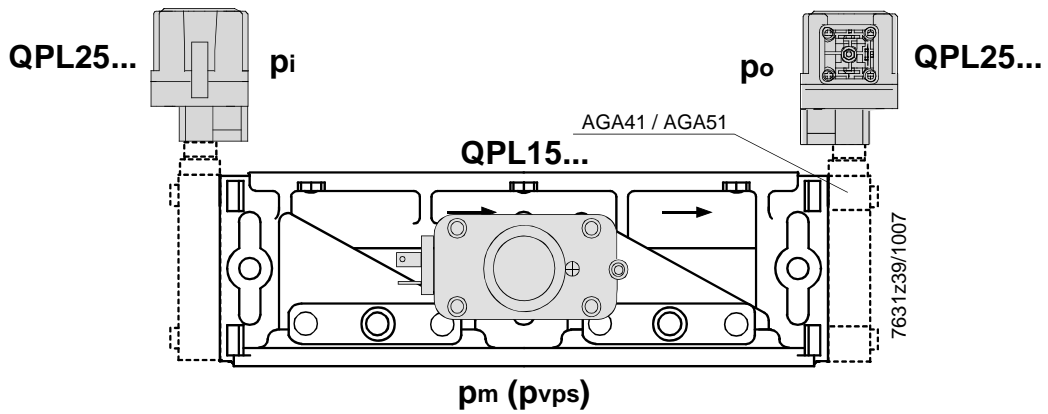

Example: Possibilities of fitting the pressure switch to the VGD4...

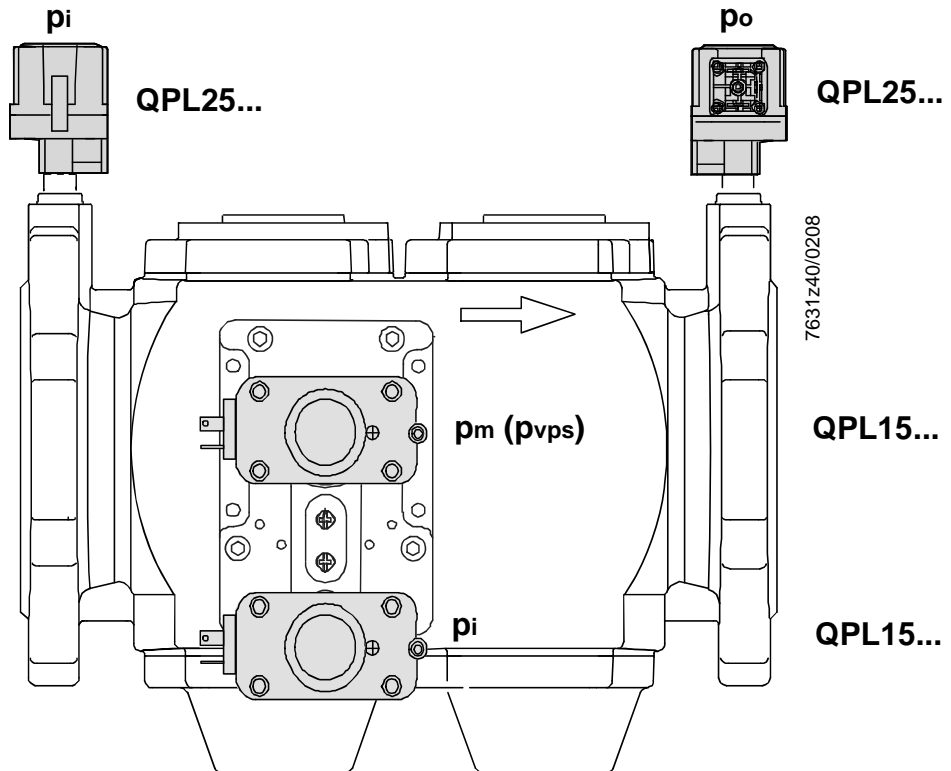

Legend

- pi = inlet pressure
- po = outlet pressure
- pm = mid-chamber pressure
- pvps = valve proving check

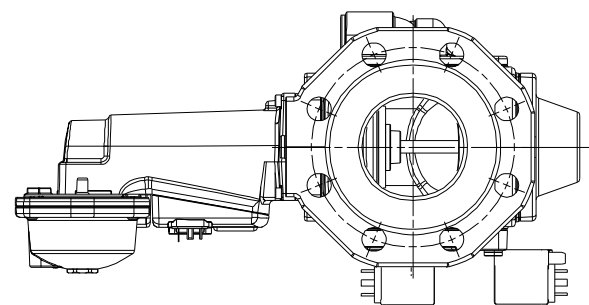
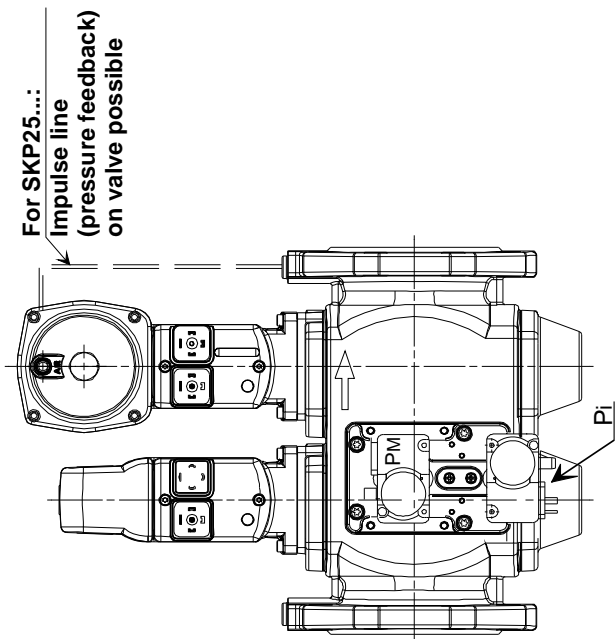

7631z34e/0208

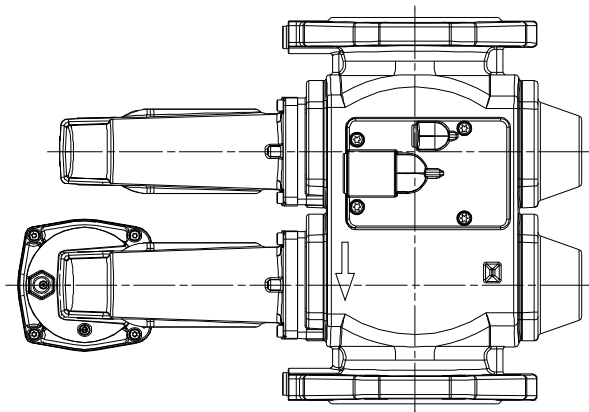

Ancillary unit options (use of different types of valve proving systems on request):

Valve proving device "A" and pressure switch (Pi)

Valve proving device "B" and pressure switch (Pi)

Valve proving device "A"

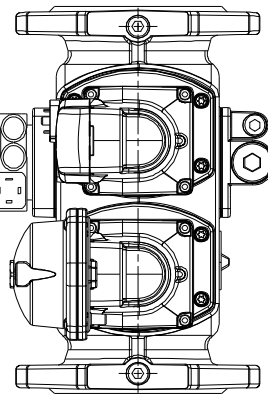

2 pressure switches (PM, Pi)

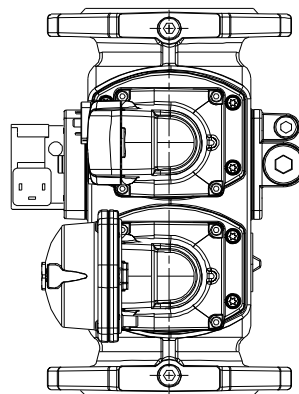

Valve proving device "B"
(only up to size 100)

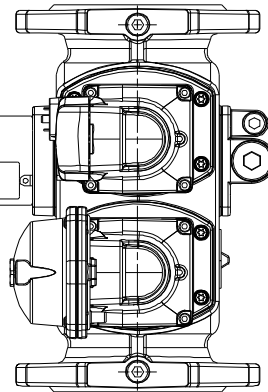

(Some of the ancillary units are products of other manufacture)

Flow chart of VGD... (only for fully open double valves)

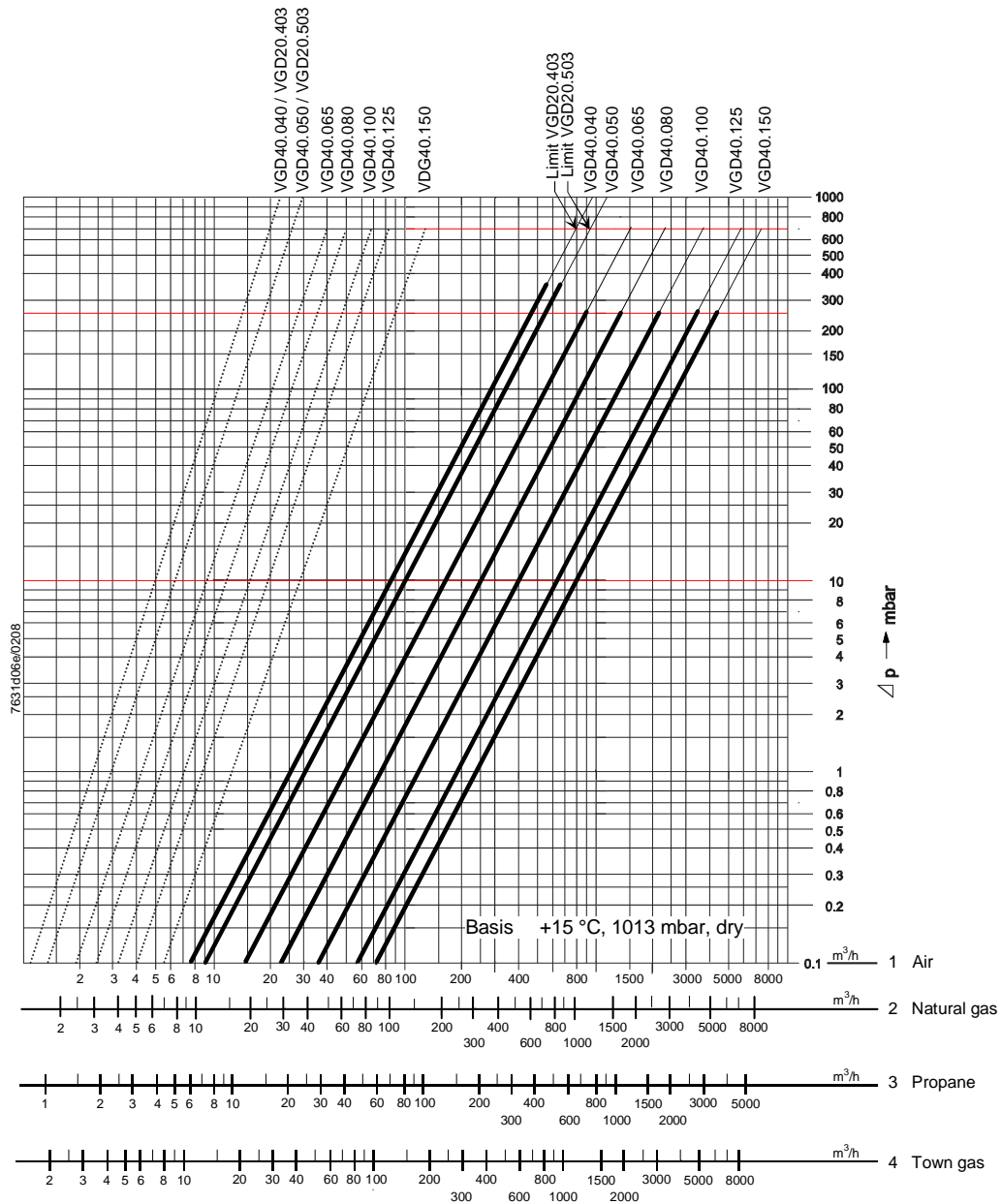

Legend:

- Minimum flow characteristic
- Maximum flow characteristic (double gas valve fully open)

Operation beyond the range confined by the bold characteristics can lead to flow noise!



Attention!

- In the case of burners with small low-fire volumes, select a tightly sized valve (refer to the relevant Data Sheets on actuators)
- If the gas pressure exceeds the maximum permissible operating pressure, reduce it with a pressure regulator installed upstream of the valve
- The pressure drop (at maximum flow) is based on a fully open valve

Conversion of the air volume to a corresponding gas volume (natural gas)

Basis of scale

Abscissa	Medium Volumetric flow (QG) in m³/h	Density ratio (dv) to air	Conversion factor $f = \sqrt{\frac{1}{d_v}}$
1	Air	1	1
2	Natural gas	0.61	1.28
3	Propane	1.562	0.8
4	Town gas	0.46	1.47

Conversion to air (m³/h) from other types of gases:

$$QL = \frac{QG}{f} \quad QL = \text{amount of air m}^3/\text{h producing the same pressure drop as } QG$$

Example: Recommended working range (extract of VGD... flow chart)

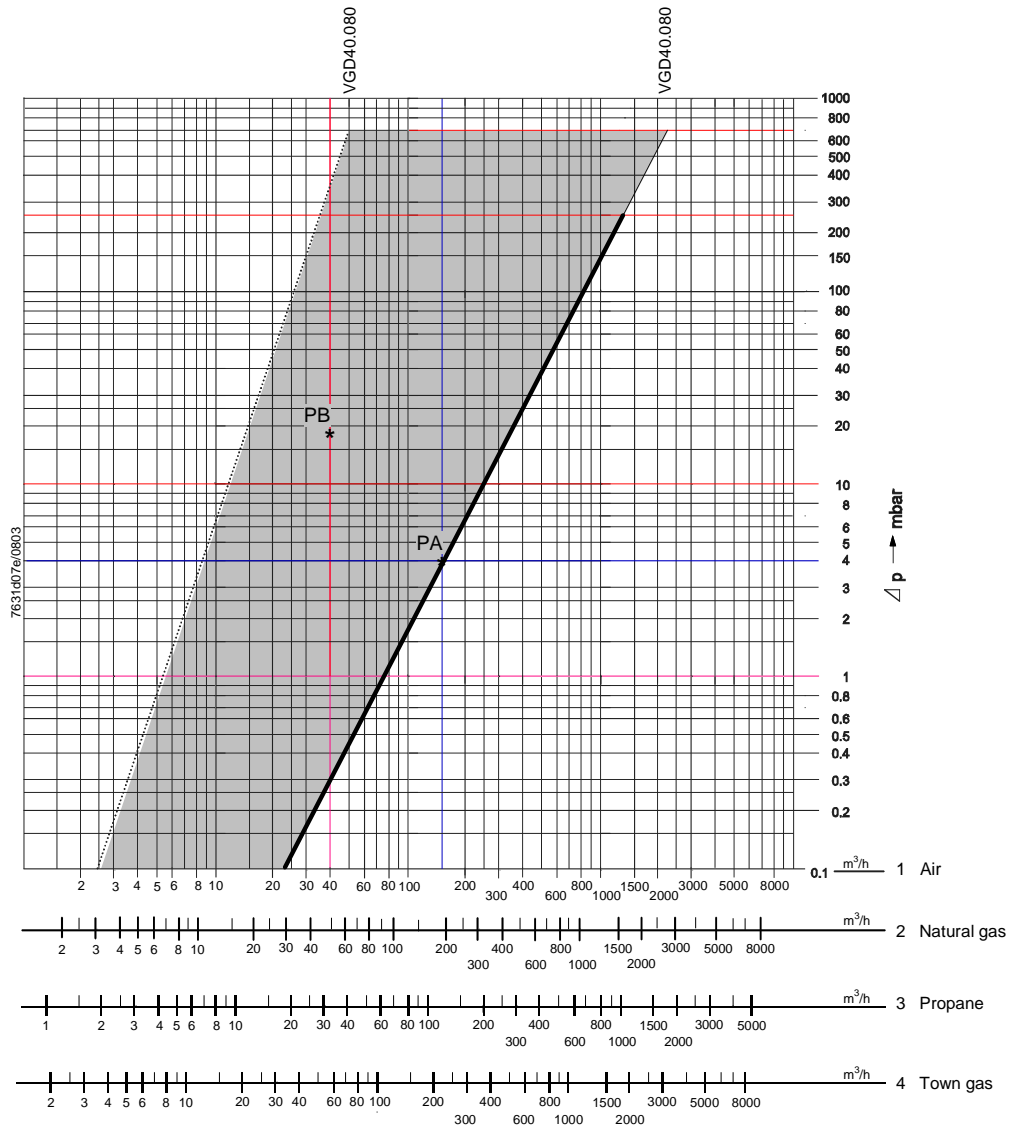

- Legend**
- Minimum flow characteristic (can vary, depending of the quality of the pressure test points)
 - Maximum flow characteristic (double gas valve fully open)
 - PA Working point
 - PB Working point

For points **PA/PB**, refer to «Sizing example» below.

Sizing example

Simplified example based on the above sizing chart: VGD... with SKP75...

Prerequisite	Burner gas outlet toward the combustion chamber
Simplified example: Constant combustion chamber pressure	= 0 mbar
Required control ratio	RV = 4:1
Gas inlet pressure	20 mbar

1. **High-fire** → Point **PA** in the highlighted area
 Burner pressure at nominal load 16 mbar
 Volumetric flow at nominal load 200 m³/h natural gas, corresponding to 156 m³/h air
 - ΔpV... at nominal load 20 - 16 = 4 mbar
 Point **PA** must be on or to the left of the line representing the maximum flow characteristic
2. **Low-fire** → Point **PB** in the highlighted area
 $PG_{min} = \frac{PG_{max}}{RV^2} = \frac{16 \text{ mbar}}{16} = 1 \text{ mbar}$ (Δp chart = 20 - 1 = 19 mbar)
 $VG_{min} = \frac{VG_{max}}{RV} = \frac{200 \text{ m}^3/\text{h}}{4} = 50 \text{ m}^3$ corresponding to $h = 39 \text{ m}^3/\text{h}$ air
 – Selected valve size VGD40.080
 Point **PB** must be on or to the right of the line representing the minimum flow characteristic.

Dimensions (not to scale)

Dimensions in mm

VGD20.403/VGD20.503

Z: VGD20.403 G / RP 3/4"
 VGD20.503 G / RP 3/4"
 VGD20.503A G / RP 1"

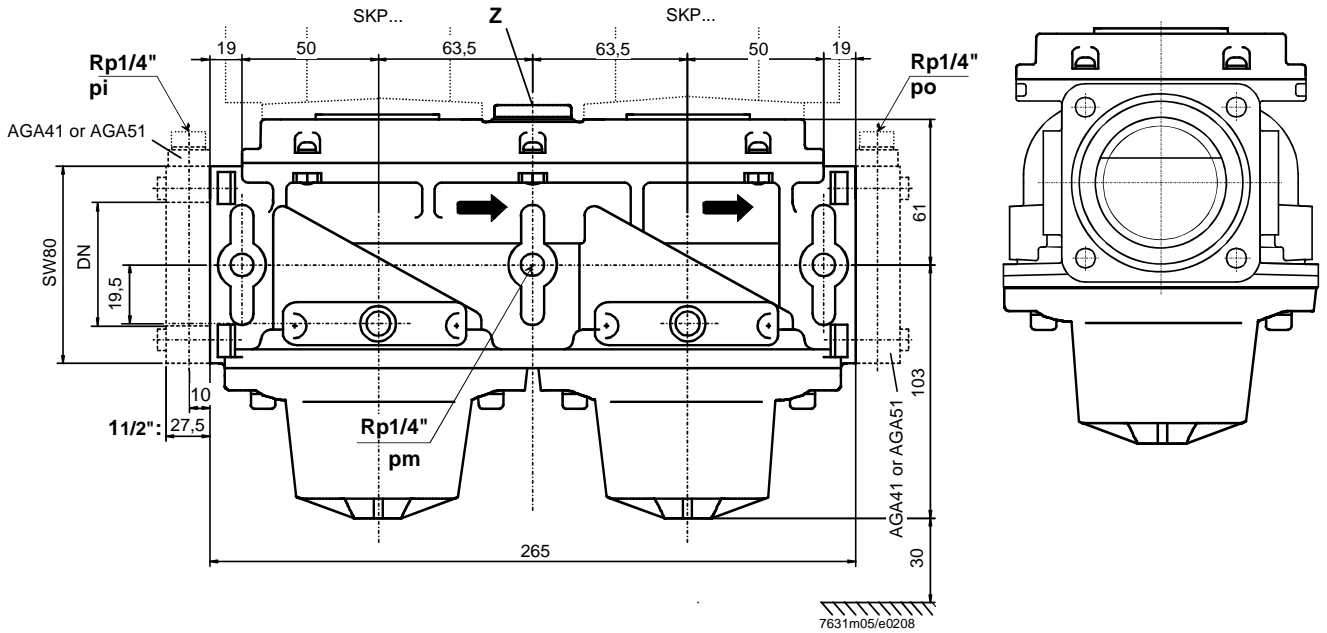

VGD20.4011/VGD20.5011 (for dimensions, refer to VGD20.403/VGD20.503)

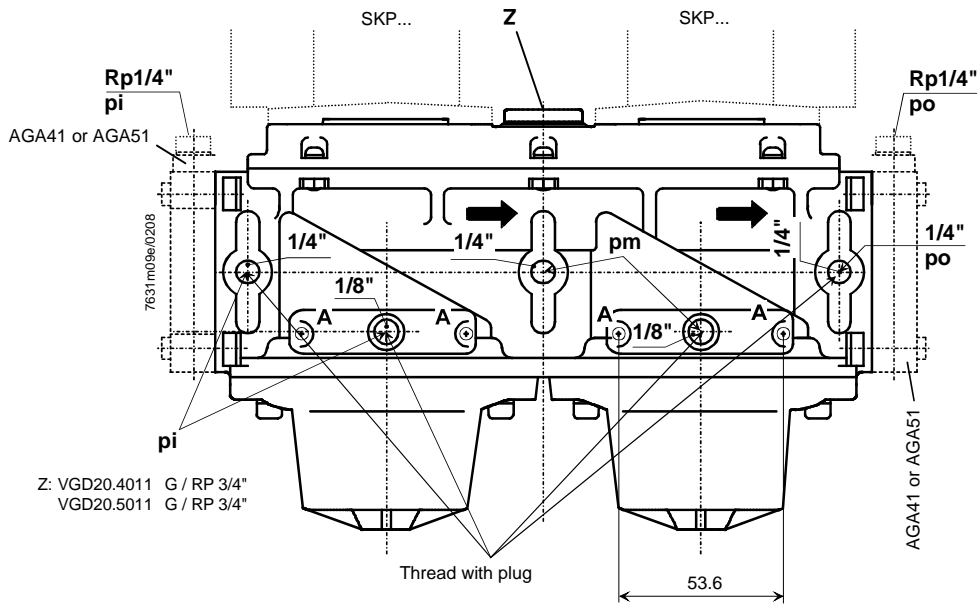

Z: VGD20.4011 G / RP 3/4"
 VGD20.5011 G / RP 3/4"



Note!
 A = hole for fitting the pressure switch (cheese-head crew M4 self-tapping)!

Dimensions (cont'd)

(Not to scale)

VGD40.../VGD41...

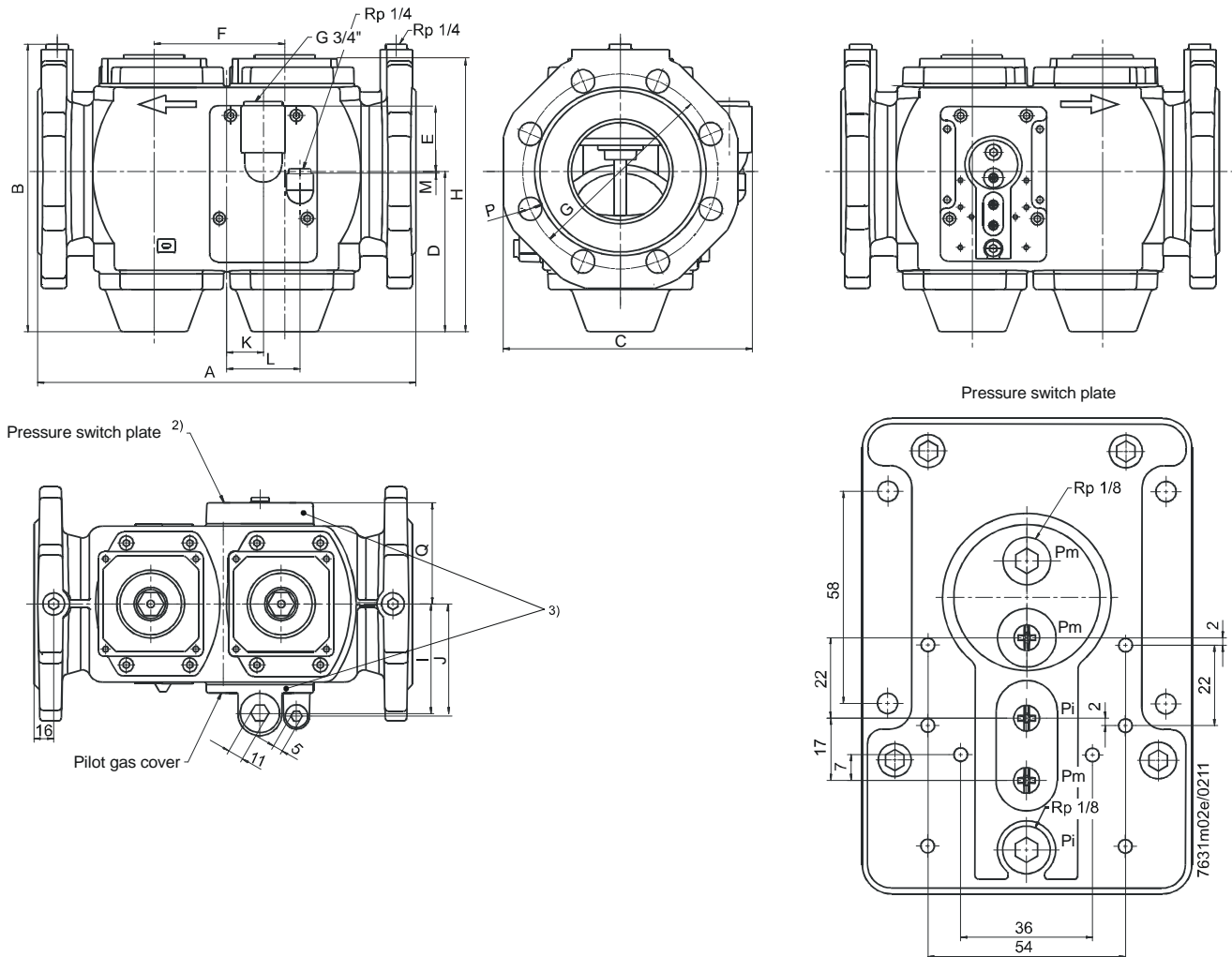

Dimensions

Type	DN ¹⁾	A	B	C	D	E	F	G	H	I	J	K	L	M	P	Q	R	kg
VGD40.040	40	240	195	168	115	58	88	110	194	77	79	20	50	2	19	70	4	7.0
VGD40.050	50	240	202	174	115	58	88	125	194	77	79	20	50	2	19	70	4	7.2
VGD40.065	65	290	215	194	118	60	102	145	200	87	90	30	60	4	19	81	4	8.4
VGD40.080	80	310	236	204	132	54	107	160	224	90	92	30	60	2	19	88	8	9.6
VGD40.100	100	350	259	227	145	43	131	180	255	105	108	41	71	13	19	99	8	12.9
VGD40.125	125	400	305	255	175	31	150	210	303	119	122	41	71	25	19	113	8	18.2
VGD40.150	150	480	335	293	188	20	168	240	333	140	143	39	69	36	23	134	8	24.1

- 1) Flanges conforming to ISO 7005-2
 - 2) VGD41... carries a pressure switch plate on both sides and no pilot gas cover
 - 3) With VGD40...L, the mounting position of the 2 plates is reversed
- DN Nominal size, dimensions of connection
R Number of bore-holes in the flange