

Technical Information

- CV Check Valves
- SH Shuttle Valves
- LM Load/Motor Controls
- FC Flow Controls
- PC Pressure Controls
- LE Logic Elements
- DC Directional Controls
- MV Manual Valves
- SV Solenoid Valves
- PV Proportional Valves
- CE Coils & Electronics
- BC Bore & Cavities
- TD Technical Data

General Description

Threaded Cartridge Style Counterbalance Valve. Pilot assisted, designed for motion control applications. For additional information see Technical Tips on pages LM1-LM4.

Features

- Poppet construction for minimal leakage
- Incorporates direct acting relief valve for overload protection
- Includes reverse check valve within body, saving space and minimizing installation cost
- Can be directly mounted into cylinder eliminating requirement for manifold block
- Fully sealed pilot for high efficiency and accurate pilot ratio
- Two pilot ratios available, 4.5:1 for cylinders and 8:1 for motor control
- Adjustable and tamper resistant versions available
- Preset version is tamper resistant and compact
- All external parts zinc plated

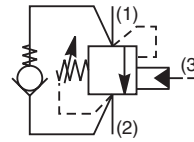
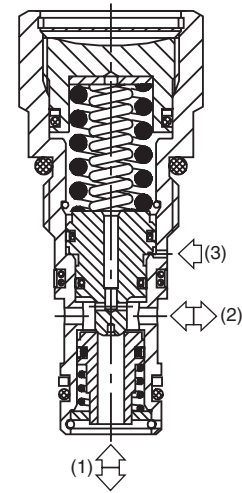
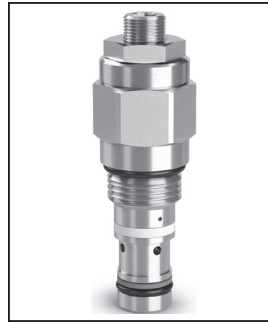

Specifications

Rated Flow	E2A020 14 LPM (3.7 GPM) E2B020 20 LPM (5.3 GPM)
Pressure	50 - 420 Bar (725 - 6000 PSI)
Sensitivity: Pressure/Turn	E2A020 113 Bar (1640 PSI) E2B020 84 Bar (1220 PSI)
Pilot Ratio	E2A020 - 8 : 1 E2B020 - 4.5 : 1
Cartridge Material	All parts steel. All operating parts hardened steel.
Operating Temp. Range/Seals	-34°C to +121°C (Nitrile) (-30°F to +250°F) -26°C to +204°C (Fluorocarbon) (-15°F to +400°F)
Fluid Compatibility/ Viscosity	Mineral-based or synthetic with lubricating properties at viscosities of 45 to 2000 SSU (6 to 420 cSt)
Filtration	ISO-4406 18/16/13, SAE Class 4
Approx. Weight	0.08 kg (0.17 lbs.)
Cavity	53-1 (See BC Section for more details)

Performance Curves

Relief & Pilot Performance 1 to 2

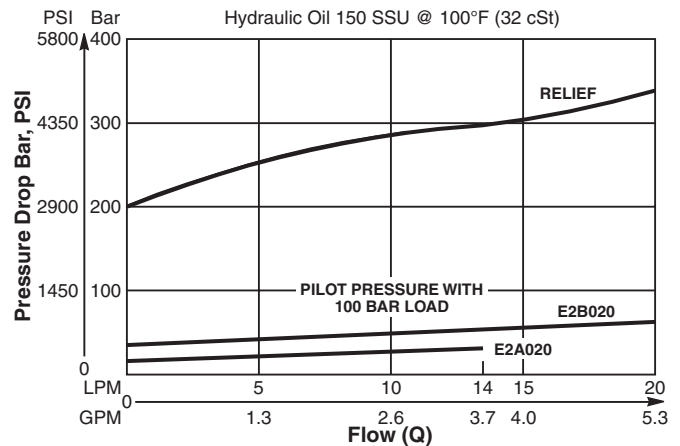

Pressure Drop vs Flow

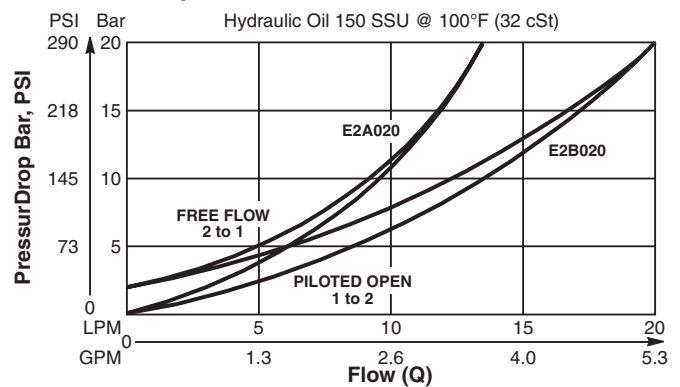

Dimensions Millimeters (Inches)

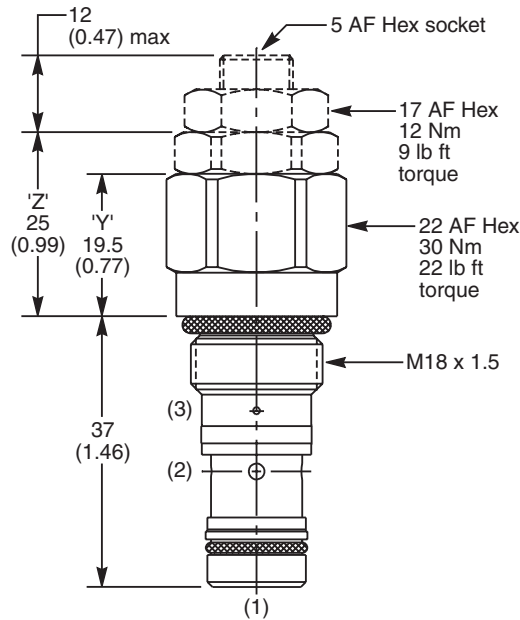

Ordering Information

E2		020			
Load Control Valve	Pilot Ratio	Adjustment Style	Cracking Pressure	Seals	

Code	Pilot Ratio
A	8 : 1
B	4.5 : 1

Code	Cracking Pressure
	Omit for no setting (Standard)* Specify setting if required

**Standard valve is set to crack at 215 Bar (3120 PSI). Valve to be set to 1.3 times maximum load induced pressure.*

Code	Adjustment Style / Kit No.
Z	Screw Adjust
T	Tamper Resistant (TC1125)
Y	Preset (Standard)

Code	Seals / Kit No.
N	Nitrile, Buna-N (Std.) / (SK30087N-1)
V	Fluorocarbon / (SK30087V-1)

Order Bodies Separately

LB10		
Line Body	Porting	Body Material

Code	Porting
318	3/8" SAE (main) 1/4" SAE (aux)
319	3/8" SAE Dual Cavity

Code	Body Material
A	Aluminum
S	Steel