

Cilindri idraulici a tiranti, conformi alla normativa ISO 6020/2, anche per uso con sensori magnetici.

Disponibili in tutti gli ancoraggi previsti dalla normativa, in molteplici configurazioni di guarnizioni, in base alle condizioni di utilizzo e alle prestazioni desiderate.

Tutti i cilindri sono testati prima della consegna in conformità alla normativa ISO 10100.

Per corse superiori a 2000 mm, è consigliabile scegliere la serie HD / HK (vedi pagina 16)

Tie rods hydraulic cylinder, in compliance with the ISO 6020/2 standard, also available with magnetic sensors.

All standard ISO mountings are available, in several seal configurations, depending on application conditions and desired performances.

All cylinders are tested in compliance with the ISO 10100 standard.

In the event of strokes longer than 2000 mm, we recommend the use of the cylinders series HD / HK (see page 16).

CD/DK

1



CARATTERISTICHE TECNICHE		SPECIFICATIONS	
Cilindri a norma Standard cylinders	ISO 6020/2 - DIN 24554 a tiranti / tie rods		
Alesaggi Bore	mm	da 25 a 100 from 25 to 100	CD da 125 a 200 from 125 to 200 DK
Pressione Pressure	bar	nominale operating 160	max 210
Corsa massima Max stroke	mm	4000	
Tolleranza sulla corsa Stroke tolerance	0 + 2 mm Norma ISO 8131 ISO 8131 Standard		
Fluido Fluid	Olio idraulico minerale Esteri fosforici Acqua glicole		
Viscosità Viscosity	12... 90 mm ² /S		

MD MAGNETICO / MAGNETIC



CARATTERISTICHE TECNICHE		SPECIFICATIONS	
Cilindri a norma Standard cylinders	ISO 6020/2 - DIN 24554 a tiranti / tie rods		
Alesaggi Bore	mm	da 25 a 125 from 25 to 125	
Pressione Pressure	bar	max 160	
Temperatura fluido Fluid temperature	°C	Compatibilmente con i limiti di temperatura d'esercizio dei sensori magnetici. Compatibly with magnetic proximity switches operating temperature limits.	
Corsa massima Max stroke	mm	4000	
Tolleranza sulla corsa Stroke tolerance	0 + 2 mm Norma ISO 8131 ISO 8131 Standard		
Fluido Fluid	Olio idraulico minerale Esteri fosforici Acqua glicole		
Viscosità Viscosity	12... 90 mm ² /S		

Codice guarnizione Seal code	Prestazioni Performance				Fluido Fluid			
	Alta tenuta High sealing	Basso attrito Low friction	Velocità max Max speed	Temp °C		Olio idraulico Hydraulic oil	Esteri fosforici Phosphoric esters	Acqua glicole HFC-fluid
				Min	Max			
S	√		0,5 m/s	- 20	+ 80	√		
L		√	1 m/s	- 20	+ 80	√		
H		√	1 m/s	- 20	+ 150	√	√	
G		√	0,5 m/s	- 20	+ 80			√

CD

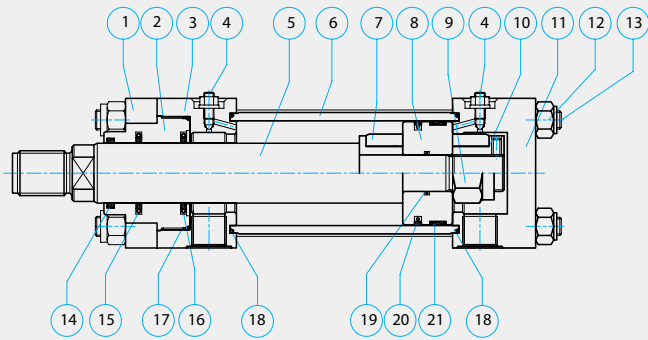

DK

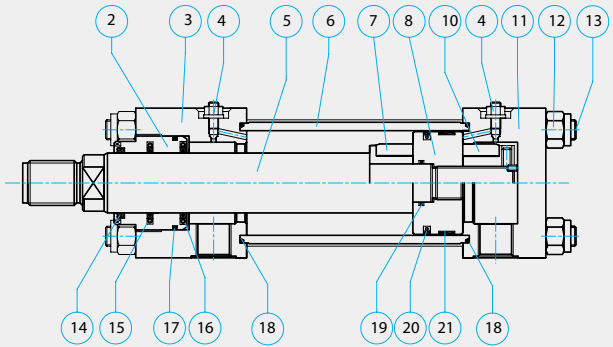

MD VERSIONE MAGNETICA

MAGNETIC VERSION

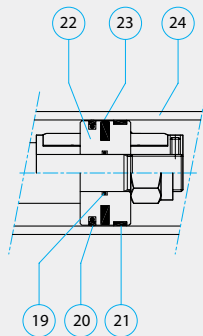

1

	Componente	Component	Materiale	Material	Specifiche	Specifications
1	Flangia chiusura	Closing flange	Acciaio	Steel		Brunito / Burnished
2	Boccola di guida	Guide bushing	Bronzo	Bronze		
3	Testata anteriore	Front head	Acciaio	Steel		Brunito / Burnished
4	Spillo regolazione frenatura + sfiato	Cushioning adjusting + air bleed	Acciaio	Steel		
5	Stelo	Piston rod	Acciaio cromato	Chromeplated steel		Cr 25 µm ISO f7 - Ra 0.20 µm
6	Canna	Cylinder body	Acciaio	Steel		Levigato / Honed H8 - Ra 0.40 µm
7	Freno anteriore	Front cushioning	Acciaio temprato	Hardened steel		
8	Pistone	Piston	Acciaio	Steel		
9	Dado autobloccante stelo	Rod self-locking nut	Acciaio	Steel		
10	Freno posteriore	Rear cushioning	Acciaio temprato	Hardened steel		
11	Testata posteriore	Rear head	Acciaio	Steel		Brunito / Burnished
12	Dado autobloccante tirante	Tie-rod self-locking nut	Acciaio	Steel		
13	Tirante	Tie-rod	Acciaio legato	Alloy steel		Filettati rullati / Rolled threaded
22	Pistone magnetico	Magnetic piston	Acciaio INOX	Stainless steel		
23	Magnete	Magnet				
24	Canna	Cylinder body	Acciaio INOX	Stainless steel		

	Componente	Component	Cava	Groove	Materiale				Material			
					S	L	H	G				
14	Raschiatore stelo	Rod wiper			NBR + PTFE	NBR + PTFE	Viton® + PTFE	NBR + PTFE CG				
15	Guarnizione stelo	Rod seal	ISO 7425/2		NBR + PTFE	NBR + PTFE	Viton® + PTFE	NBR + PTFE CG				
16	Guarnizione stelo	Rod seal	ISO 7425/2		PU	NBR + PTFE	Viton® + PTFE	NBR + PTFE CG				
17	Guarnizione testata-boccola	Head-bushing sealing			NBR + PTFE	NBR + PTFE	Viton® + PTFE	NBR + PTFE CG				
18	Guarnizione canna	Tube seal			NBR	NBR	Viton®	NBR				
19	Guarnizione pistone	Piston seal			NBR	NBR	Viton®	NBR				
20	Guarnizione pistone	Piston seal	ISO 7425/1		NBR + PU	NBR + PTFE	Viton® + PTFE	NBR + PTFE CG				
21	Guida pistone	Piston guide			Resina Resin	Resina Resin	Resina Resin	Resina Resin				

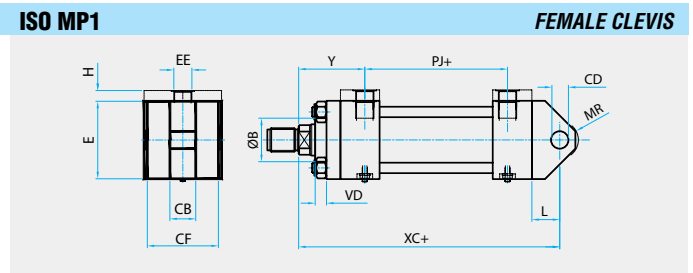
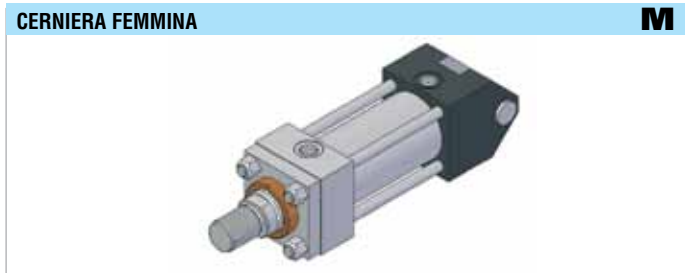
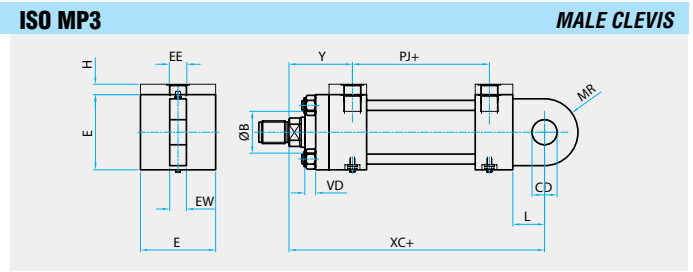
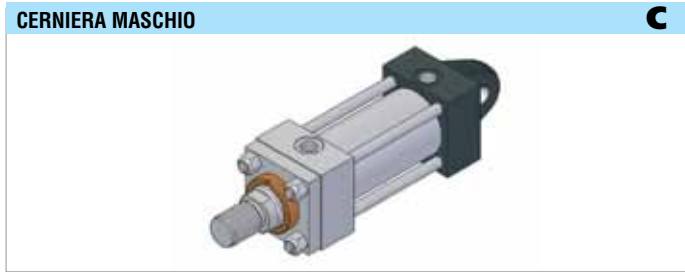
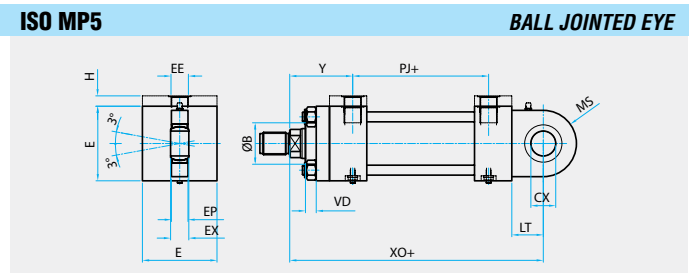
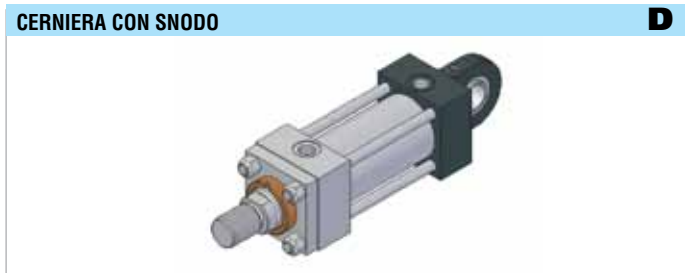
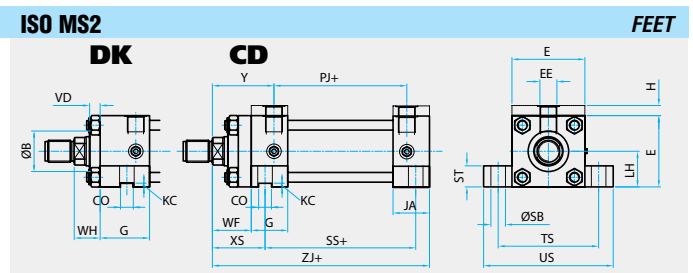
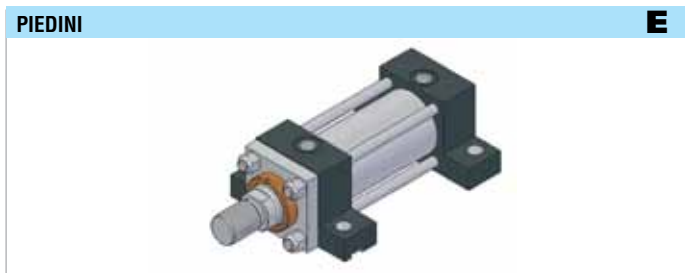
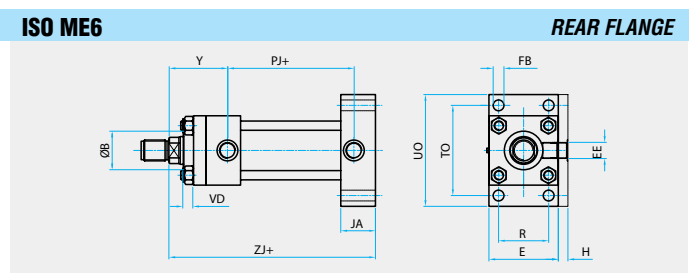
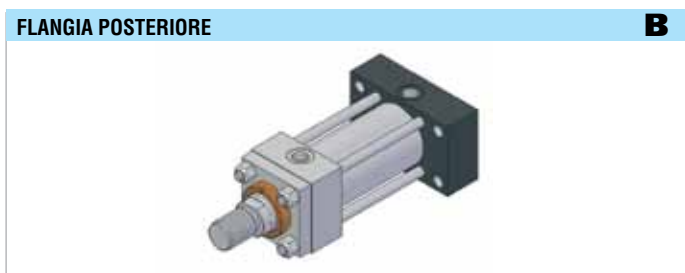
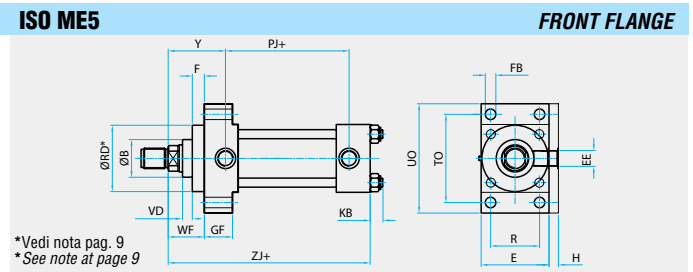
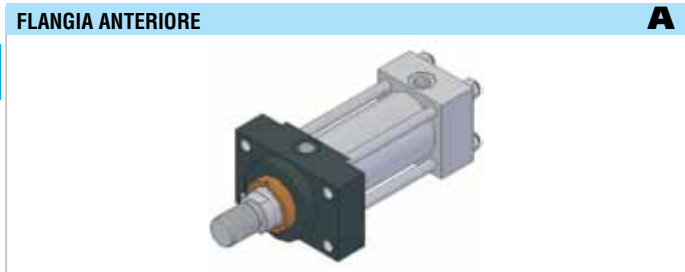
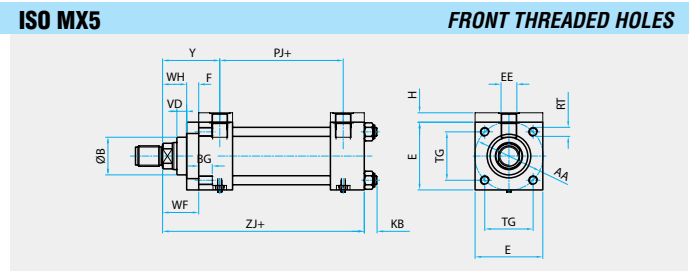
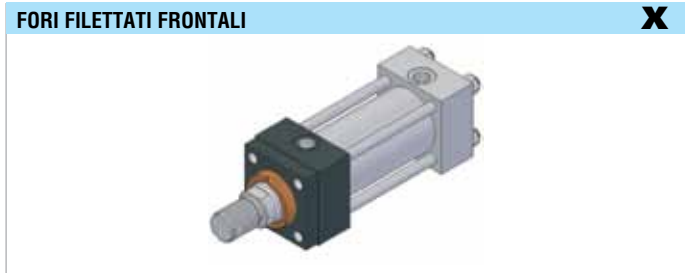

PERNI ANTERIORI

G

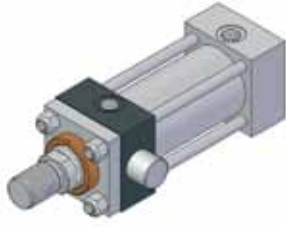

ISO MT1

FRONT TRUNNIONS

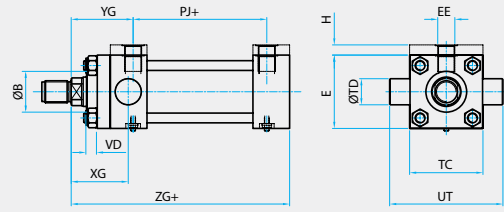

PERNI INTERMEDI

H

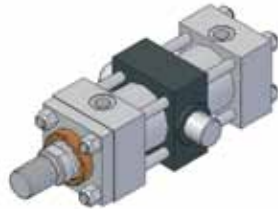

ISO MT4

INTERMEDIATE TRUNNIONS

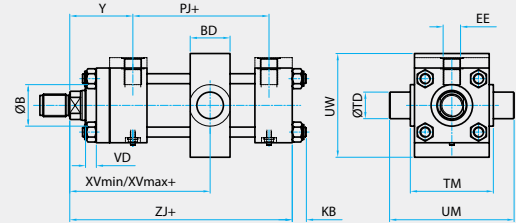

PERNI POSTERIORI

L



ISO MT2

REAR TRUNNIONS

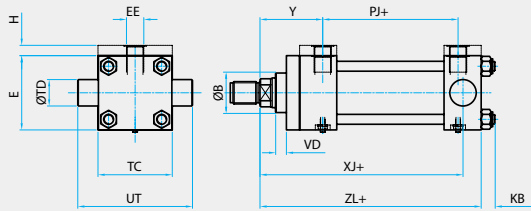

TIRANTI PROLUNGATI ANTERIORI E POSTERIORI

Q



ISO MX1

FRONT AND REAR EXTENDED TIE-RODS

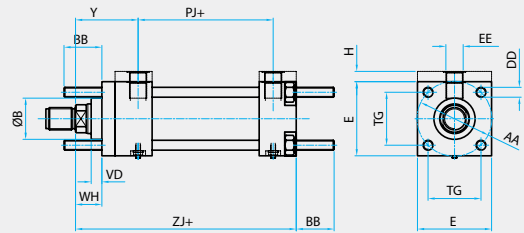

TIRANTI PROLUNGATI ANTERIORI

R

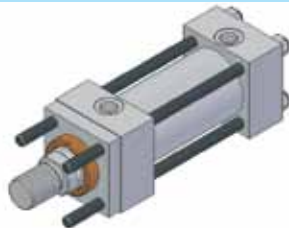

ISO MX3

EXTENDED FRONT TIE-RODS

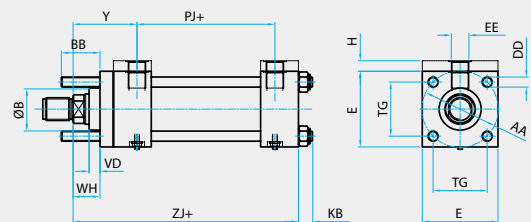

TIRANTI PROLUNGATI POSTERIORI

S



ISO MX2

EXTENDED REAR TIE-RODS

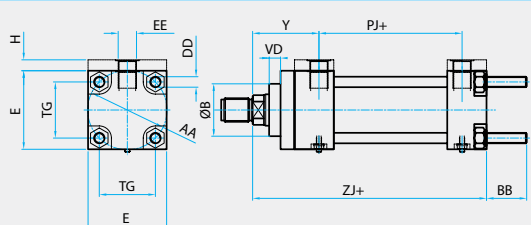

FORI FILETTATI POSTERIORI

T



ISO MX6

REAR THREADED HOLES

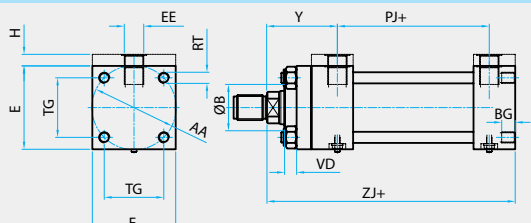

FORI FILETTATI FRONTALI

X

FRONT THREADED HOLES

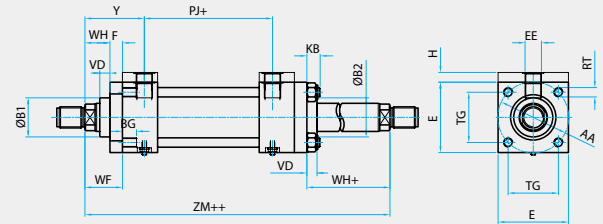
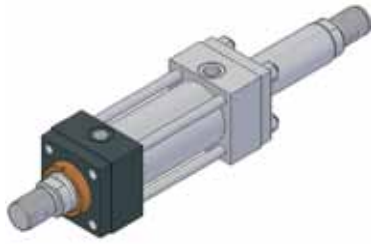

1

FLANGIA ANTERIORE

A

FRONT FLANGE

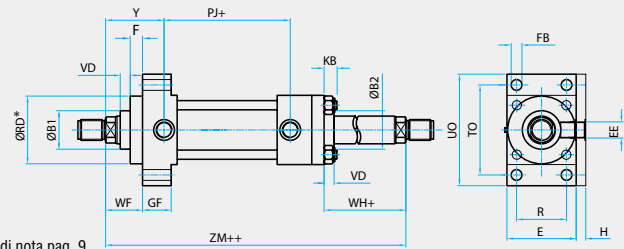
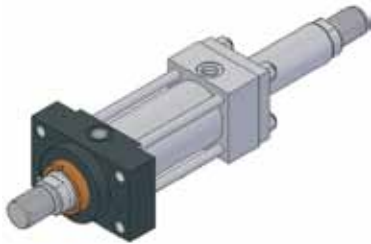

*Vedi nota pag. 9
* See note at page 9

PIEDINI

E

FEET

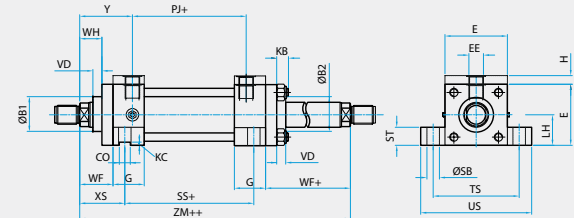

PERNI ANTERIORI

G

FRONT TRUNNIONS

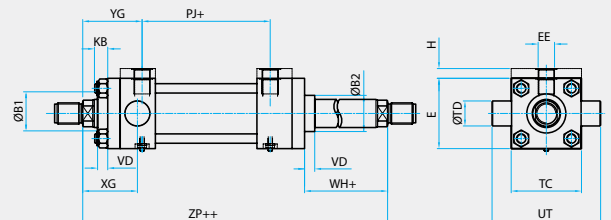
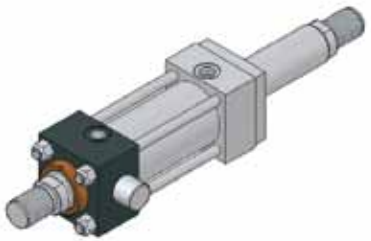

PERNI INTERMEDI

H

INTERMEDIATE TRUNNIONS

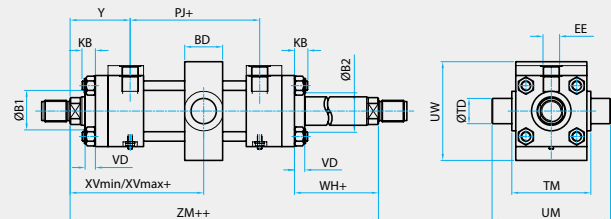
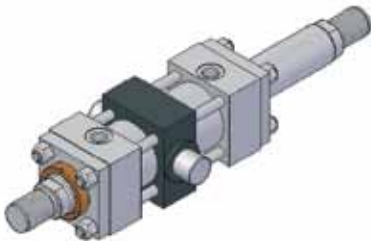

TIRANTI PROLUNGATI ANTERIORI E POSTERIORI

Q

FRONT AND REAR EXTENDED TIE-RODS

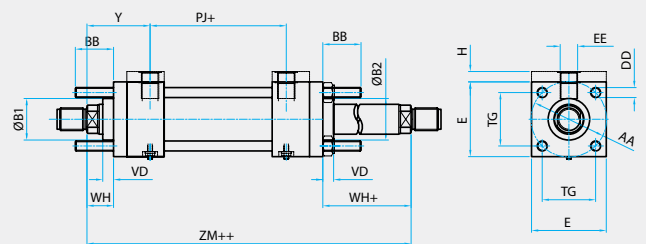
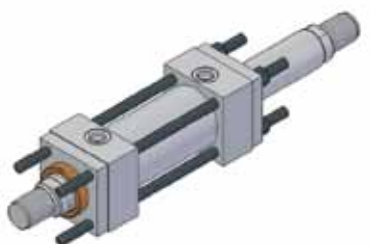

Alesaggio Bore	25		32			40			50			63			80			100			125			160			200		
	Stelo Rod	12	18	14	18	22	18	22	28	22	28	36	28	36	45	36	45	56	45	56	70	56	70	90	70	90	110	90	110
B f9	24	30	26	30	34	30	34	42	34	42	50	42	50	60	50	60	72	60	72	88	72	88	108	88	108	133	108	133	163
AA	40		47			59			74			91			117			137			178			219			269		
BB	19		24			35			46			46			59			59			81			92			115		
BD	20		25			29			38			48			58			68			88			108			125		
BG	12		15			16			18			18			24			24			30			35			40		
CB	16(*)		16			20			30			30			40			50			64(*)			80(*)			80		
CD h8	10		12			14			20			20			28			36			45			56			70		
CF	40		45			60			74			90			110			130			164			200			240		
CO H8	—		—			12			12			16			16			16			20			30			40		
CX	12 -0.008		16 -0.008			20 -0.012			25 -0.012			30 -0.012			40 -0.012			50 -0.012			60 -0.015			80 -0.015			100 -0.020		
DD	M5x0.8		M6x1			M8x1			M12x1.25			M12x1.25			M16x1.5			M16x1.5			M22x1.5			M27x2			M30x2		
E max	40		45			60			75			90			115			130			165			200			245		
EE	G 1/4"		G 1/4"			G 3/8"			G 1/2"			G 1/2"			G 3/4"			G 3/4"			G 1"			G 1"			G 1 1/4"		
EP	9		12			14			18			20			24			30			38			47			58		
EW h14	12		16			20			30			30			40			50			60			70			80		
EX	10		14			16			20			22			28			35			44			55			70		
F	10		10			10			16			16			20			22			22			25			25		
FB H13	5.5		6.6			11			14			14			18			18			22			26			33		
G	32		35.5			46			45			45			52			55			87			95			117		
GF	25		25			38			38			38			45			45			58			58			76		
H	5		5			—			—			—			—			—			—			—			—		
JA	32		35.5			46			45			45			52			55			65			70			92		
KB	7		10			13			17			17			23			23			30			35			37		
KC	—		—			4			4.5			4.5			5			6			6			8			8		
L	13		19			19			32			32			39			54			57			63			82		
LH h10	19		22			31			37			44			57			63			82			101			122		
LT	16		20			25			31			38			48			58			72			92			116		
MR max	12		17			17			29			29			34			50			53			59			78		
MS max	20		22.5			29			33			40			50			62			80			100			120		
PJ	49+ (*)		47+ (*)			58+ (*)			62+ (*)			64+ (*)			77+ (*)			78+ (*)			117+			130+			165+		
R	27		33			41			52			65			83			97			126			155			190		
RD f8	38		42			62			74			88 (**)			105 (**)			125 (**)			150 (**)			170 (**)			210 (**)		
RT	M5		M6			M8			M12			M12			M16			M16			M22			M27			M30		
SB H13	6.6		9			11			14			18			18			26			26			33			39		
SS	73+		73+			98+			92+			86+			105+			102+			131+			130+			172+		
ST	8.5		12.5			12.5			19			26			26			32			32			38			44		
TC	38		44			63			76			89			114			127			165			203			241		
TD f8	12		16			20			25			32			40			50			63			80			100		
TG	28.3		33.2			41.7			52.3			64.3			82.7			96.9			125.9			154.9			190.2		
TM	48		55			76			89			100			127			140			178			215			279		
TO	51		58			87			105			117			149			162			208			253			300		
TS	54		63			83			102			124			149			172			210			260			311		
UM	68		79			108			129			150			191			220			278			341			439		
UO	65		70			110			130			145			180			200			250			300			360		
US	72		84			103			127			161			186			216			254			318			381		
UT	58		68			95			116			139			178			207			265			329			401		
UW	45		50			70			90			100			130			140			180			215			300		
VD	6		12			12			9			13			9			10			10			7			7		
WF	25		35			35			41			48			51			57			57			57			57		
WH	15		25			25			25			32			31			35			35			32			32		
XC	127+		147+			172+			191+			200+			229+			257+			289+			308+			381+		
XG	44		54			57			64			70			76			71			75			75			85		
XJ	95+ (*)		109+ (*)			131+ (*)			136+ (*)			146+ (*)			165+ (*)			177+ (*)			214+ (*)			227+ (*)			271+ (*)		
XO	130+		148+			178+			190+			206+			238+			261+			304+			337+			415+		
XS	33		45			45			54			65			68			79			79			86			92		
XV min / max	67 / 72+		83 / 80+			96 / 92+			106 / 94+			118 / 98+			133 / 108+			147 / 113+			166 / 123+			182 / 120+			213 / 142+		
Y	45 (*)		58 (*)			65 (*)			69 (*)			76 (*)			82 (*)			91 (*)			86			86			98		
YG	45 (*)		58 (*)			65 (*)			69 (*)			76 (*)			82 (*)			79 (*)			86			86			98		
ZG	114+		128+			153+			159+			168+			190+			191+			232+			245+			299+		
ZJ	114+		128+			153+			159+			168+			190+			203+			232+			245+			299+		
ZL	114+		128+			153+			159+			168+			190+			203+			254+			270+			324+		
ZM	139++		163++			188++			200++			216++			241++			260++			289++			302++			356++		
ZP	139++		163++			188++			200++			216++			241++			248++			289++			302++			356++		

1

(*) Non conforme a ISO 6020/2
Does not comply with ISO 6020/2 standard

(**) Quota RD unificata, con riferimento allo stelo maggiore rispetto a quelli previsti dalla norma ISO 6020/2. RD speciale su richiesta.
RD dimension is unified, with reference to the higher diameter between the ones defined by ISO 6020/2 standard. Special RD dimension on request.

+ = sommare la corsa
add the stroke

++ = sommare il doppio della corsa
add the double of the stroke

ISO 6020/2

STANDARD

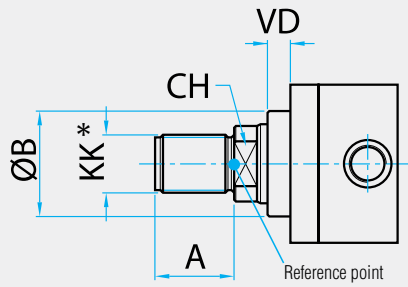

SF

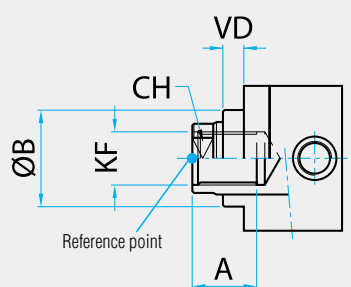

ST

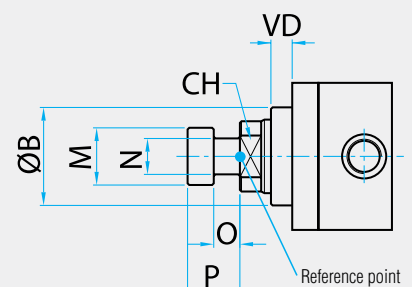

Stelo / Rod	12	14	18	22	28	36	45	56	70	90	110	140
A	14	16	18	22	28	36	45	56	63	85	95	112
B f9	24	26	30	34	42	50	60	72	88	108	133	163
CH	10	12	15	19	22	30	36	46	60	75	95	120
KK	M10x1.25	M12x1.25	M14x1.5	M16x1.5	M20x1.5	M27x2	M33x2	M42x2	M48x2	M64x3	M80x3	M100x3
KF	M8x1	M10x1.25	M12x1.25	M16x1.5	M20x1.5	M27x2	M33x2	M42x2	M48x2	M64x3	M80x3	M100x3
M	11	13	16	18	22	28	35	45	56	70	106	136
N	6.5	8	10	11	14	18	22	28	35	45	65	70
O	5	6	7	8	10	13	16	20	25	35	35	45
P	10	12	14	16	20	25	32	40	50	70	70	90

* Per l'estremità stelo standard maschio, il terminale stelo con snodo sferico più adatto è la versione CS (vedi pagina 40).

* For the standard male rod end, the most suitable rod end eye with spherical bearing is the CS version (see page 40).

DIN 24554

SL

DIN 24554

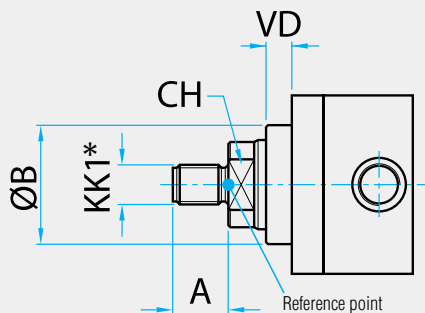

Alesaggio Bore	25		32			40			50			63			80			100			125			160			200		
Stelo Rod	12	18	14	18	22	18	22	28	22	28	36	28	36	45	36	45	56	45	56	70	56	70	90	70	90	110	90	110	140
A	14	16	16	18	18	18	22	22	22	28	28	28	36	36	36	45	45	45	56	56	56	63	63	63	70	70	70	85	
B f9	24	30	26	30	34	30	34	42	34	42	50	42	50	60	50	60	72	60	72	88	72	88	108	88	108	133	108	133	163
CH	10	15	12	15	19	15	19	22	19	22	30	22	30	36	30	36	46	36	46	60	46	60	75	60	75	95	75	95	120
KK1	M10x1.25	M12x1.25	M14x1.5	M16x1.5	M20x1.5	M27x2	M33x2	M42x2	M48x2	M64x3	M80x3	M100x3	M120x3	M160x3	M200x3	M250x3	M315x3	M400x3	M500x3	M630x3	M800x3	M1000x3	M1250x3	M1600x3	M2000x3	M2500x3	M3150x3	M4000x3	M5000x3
VD	6	12	6	12	12	9	13	9	10	10	10	10	10	10	10	10	10	10	10	10	10	10	10	10	10	10	10	10	10

* Per l'estremità stelo maschio SL, il terminale stelo con snodo sferico più adatto è la versione TS (vedi pagina 40).

* For the SL male rod end, the most suitable rod end eye with spherical bearing is the TS version (see page 40).

CODICE ORDINAZIONE / ORDERING CODE

I campi in cui sono stati inseriti i valori di esempio sono obbligatori. The fields containing sample values are compulsory.

CD **50 / 28 /** **A** **500** **S**

Serie / Type	Alesaggio / Bore	
Standard	25... 100	CD
	125... 200	DK
Magnetico / Magnetic	25... 125	MD

Esecuzione speciale / Special version (1) **SX**

		Alesaggio / Bore	Stelo / Rod
MD	CD	25	12 18
		32	14 18
		40	18 22 28
		50	22 28 36
		63	28 36 45
		80	36 45 56
	DK	100	45 56 70
		125	56 70 90
		160	70 90 110
		200	90 110 140

Eventuale 2° stelo / Possible 2nd rod

Vedi pagg. 6-8 / See pages 6-8	ISO 6020/2	DIN24554	Ancoraggio / Mounting
Fori filettati frontali / Front tapped holes	MX5		X
Flangia anteriore / Front flange	ME5	ME5	A
Flangia posteriore / Rear flange	ME6	ME6	B
Piedini / Feet	MS2	MS2	E
Cerniera con snodo / Ball jointed eye	MP5	MP5	D
Cerniera maschio / Male clevis	MP3		C
Cerniera femmina / Female clevis	MP1		M
Perni anteriori / Front trunnions	MT1		G
Perni intermedi / Intermediate trunnions (2)	MT4	MT4	H
Perni posteriori / Rear trunnions	MT2		L
Tiranti prolungati ant. e post. / Extended front and rear tie-rods	MX1		Q
Tiranti prolungati anteriori / Extended front tie-rods	MX3		R
Tiranti prolungati posteriori / Extended rear tie-rods	MX2		S
Fori filettati posteriori / Rear threaded holes	MX6		T



Solo per cilindri MD
Only for MD cylinders
(vedi pag. 15)
(see page 15)

Quantità / Quantity

Sensore / Switch	Tipo / Type
SR	REED 24-110 V. AC/DC
SH	PNP 24 V. DC

Opzioni/Esecuzioni speciali
Special options/versions
(vedi pag. 12/14)
(see page 12/14)

Sfiato aria / Air bleed	
	Nessuno sfiato / No air bleed
SV	Anteriore / Front only
SZ	Posteriore / Rear only
SK	Anteriore + posteriore / Front and rear

Estremità stelo / Rod end (vedi pag. 10 / see page 10)

	SF	Filetto maschio / Male thread (standard)
	ST	Filetto femmina / Female thread
	SL	Testa a martello / Floating joint
	SL	Filetto maschio DIN 24554 / Male thread DIN 24554

Guarnizioni / Seals (vedi pagg. 4 / See pages 4)

S	Standard (olio minerale) / Standard (mineral oil)
L	Basso attrito / Low friction
H	Viton® (alte temperature, esteri fosforici) / Viton® (high temperature, phosphoric esters)
G	Acqua glicole / HFC-fluid

Distanziale / Spacer
Consigliato per corsa: / Recommended for stroke:

	da 0 a 1000 / from 0 to 1000
SJ 50	da 1000 a 1500 / from 1000 to 1500
SJ 100	da 1500 a 2000 / from 1500 to 2000
SJ 150	da 2000 a 3000 / from 2000 to 3000
SJ 200	oltre 3000 / over 3000

Corsa / Stroke

Indicare in mm / Specify in mm

Frenatura regolabile / Adjustable cushioning

	Senza frenatura / Not cushioned
	V Anteriore / Front only
	Z Posteriore / Rear only
	K Anteriore + posteriore / Front and rear

(1) Indicare **SX** ogni qual volta il cilindro ha opzioni o esecuzioni speciali. Indicare poi nell'apposita casella, a fine codice, il corrispondente codice (vedi pag. 12) seguito da eventuale n. di disegno. Indicate **SX** when the cylinder has special options or versions. Then, indicate in the appropriate box, after the ordering code, the corresponding code (see page 12) followed by the drawing's number, if any.

(2) Per ancoraggio H (MT4), indicare in coda al codice la dicitura "XV" seguita dal valore della quota XV (vedi pagg. 7-8). For H mounting (MT4), indicate at the end of the code the letters "XV" followed by the XV quote value (see pages 7-8).

MATERIALE STELO / ROD MATERIAL

RRX	Stelo INOX cromato / <i>Stainless steel chromeplated rod</i>
RRB	Stelo bonificato cromato / <i>Hardened and tempered chromeplated rod</i>
RRK	Stelo Nikrom / <i>Nikrom rod</i>
RRH	Stelo temprato cromato / <i>Hardened chromeplated rod</i>

Per la scelta di qualsiasi opzione o variante rispetto al cilindro standard, si consiglia di utilizzare l'apposito servizio sul sito www.confortinet.com
To choose an option or a variation of the standard cylinder, please use our service available on www.confortinet.com

ORIENTAMENTO CONNESSIONI

PORT LOCATION

CONNESSIONI SAE 3000 / SAE 3000 CONNECTIONS

1

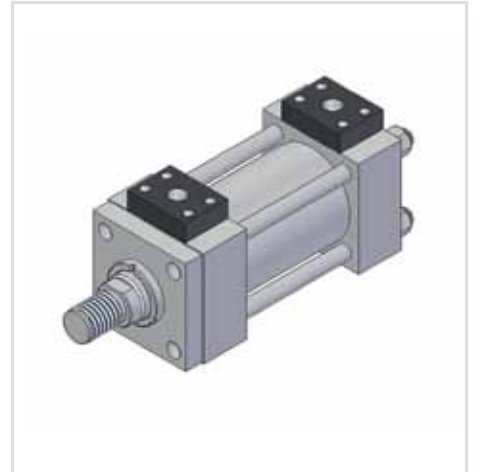
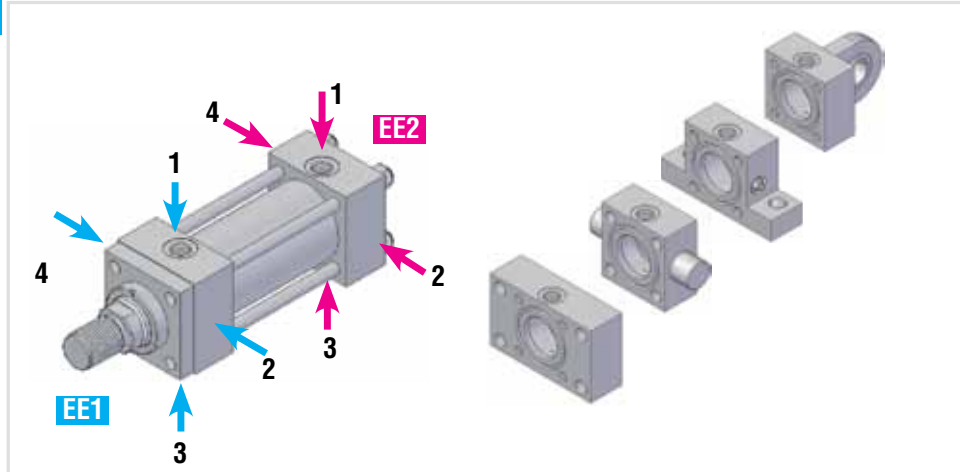

La configurazione standard prevede la porta dell'olio in posizione 1 ed eventuali grani di regolazione della frenatura o sfiati sul lato 3, ad eccezione dell'ancoraggio E in cui sono in posizione 2.
The standard configuration has the oil ports in position 1 and the cushioning adjustment or air bleed in position 3, except for the mounting type E, where they are in position 2.

Alesaggio Bore	ISO 1179-1 (GAS)				SAE 3000			
	Standard		Maggiorate / Oversize		Standard		Maggiorate / Oversize	
	Anteriore Front	Posteriore Rear	Anteriore Front	Posteriore Rear	Anteriore Front	Posteriore Rear	Anteriore Front	Posteriore Rear
25	G 1/4"	G 1/4"	—	G 3/8"	—	—	—	—
32	G 1/4"	G 1/4"	—	G 3/8"	—	—	—	—
40	G 3/8"	G 3/8"	—	G 1/2"	—	—	—	—
50	G 1/2"	G 1/2"	—	G 3/4"	—	—	—	—
63	G 1/2"	G 1/2"	—	G 3/4"	—	—	—	—
80	G 3/4"	G 3/4"	—	G 1"	3/4"	3/4"	1"	1"
100	G 3/4"	G 3/4"	—	G 1"	3/4"	3/4"	1"	1"
125	G 1"	G 1"	G 1 1/4"	G 1 1/4"	1"	1"	1 1/4"	1 1/4"
160	G 1"	G 1"	G 1 1/4"	G 1 1/4"	1"	1"	1 1/4"	1 1/4"
200	G 1 1/4"	G 1 1/4"	G 1 1/2"	G 1 1/2"	1 1/4"	1 1/4"	1 1/2"	1 1/2"

SD DRENAGGIO BOCCOLA / BUSHING DRAIN

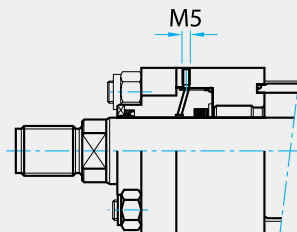

Il drenaggio della boccola impedisce l'accumulo di fluido dietro al raschiatore.
Una connessione situata tra il raschiatore e la tenuta a labbro consente il rinvio al serbatoio del fluido.
Il drenaggio è normalmente posizionato sul lato opposto alla bocca olio.

The bushing drain avoids the accumulation of liquid behind the scraper.
A connection between the scraper and the lip seal allows to send the fluid back to the tank.
The drain is usually installed on the opposite side of the oil port.

BL

Per applicazioni speciali in cui è richiesta alta tenuta e alta scorrevolezza (ad esempio, applicazioni con circuiti chiusi), è possibile utilizzare una versione speciale del pistone appositamente modificata.
Consultare il nostro ufficio tecnico per verificare l'applicabilità di questa soluzione.

For special application, where high sealing and low friction is required (i.e., closed circuit application), a special piston is available.
Contact our technical department in order to verify the feasibility of this solution.

Le piastre incorporate consentono il montaggio di valvole di controllo a quattro vie con superfici di montaggio ISO 4401.
In questo modo, i volumi d'olio tra il cilindro e la valvola vengono ridotti, ottenendo una migliore precisione di controllo.

Sono montate direttamente sulla testata posteriore del cilindro tramite quattro viti di fissaggio e un nipplo.

Sono disponibili anche in versioni con nipplo conico filettato, impiegabile anche per gli alesaggi più piccoli o in altre situazioni particolari: per informazioni, contattare il nostro ufficio tecnico.

The incorporated plate allows mounting a four port control valve with an ISO 4401 mounting surface.

In this way, the oil volumes between the cylinder and the valve are reduced, obtaining a better control precision.

They are mounted directly on the cylinder's rear head though four screws and a nipple.

They are available also in a version with conic threaded nipple, usable also for small bores or in other particular situations: for information, contact our technical department.

PIASTRE INCORPORATE: FISSAGGIO CON QUATTRO VITI / INCORPORATED PLATES: MOUNTED WITH FOUR SCREWS

BV3-A

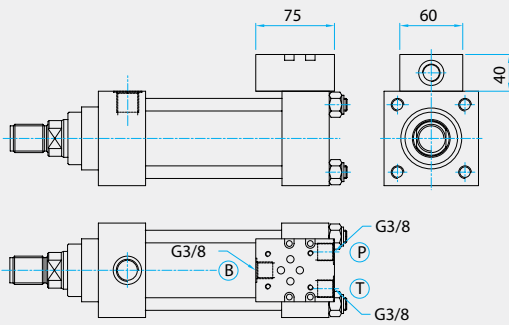

BV5-A

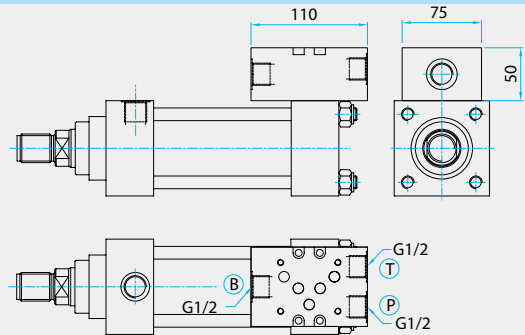

BV3-B

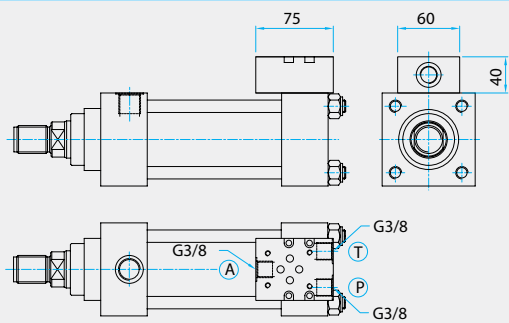

BV5-B

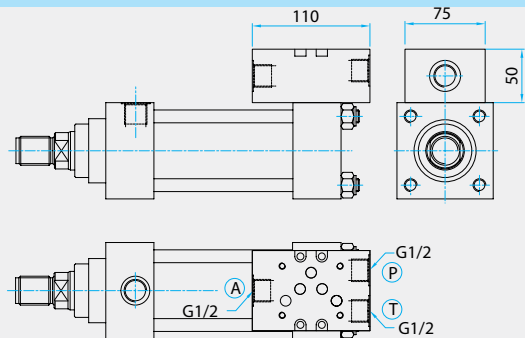

CODICE ORDINAZIONE PIASTRE INCORPORATE / INCORPORATED PLATES ORDERING CODE

I campi in cui sono stati inseriti i valori di esempio sono obbligatori.
The fields containing sample values are compulsory.

BV 3 - A

Dimensione porte olio Oil port dimension	Alesaggi Bore range			Collegamenti Link configuration
ISO 4001-03 NG6	40 - 125	3	A	Porta A ▶ lato posteriore Port A ▶ rear side
ISO 4001-05 NG10	50 - 200	5		Porta B ▶ lato posteriore Port B ▶ rear side

I sensori di prossimità possono essere utilizzati per il rilevamento della posizione del pistone in corrispondenza dell'venuto posizionamento vicino alla fine corsa del cilindro. Sono montati sulla testata del cilindro, solitamente in posizione 4 (vedi pag. 12).

Il funzionamento dei sensori è possibile solo in cilindri con alesaggi compresi tra 40 e 200 mm dotati di freni. Infatti il sensore genera un campo magnetico ed è in grado di rilevarne la variazione che deriva dall'avvicinamento della boccola freno. Il segnale di uscita è regolato da un contatto "normalmente aperto".

Proximity switches can be used to detect the piston position when it is close to stroke end. They are mounted on the cylinder head, usually in position 4 (see page 12). The proximity switches work only in cylinders with bore between 40 and 200 mm with cushioning. In fact, the proximity switch generates a magnetic field and it is able to detect its modification due to the proximity of the cushioning bushing. The output signal is modulated by a "normally open" switch.

SENSORI DI PROSSIMITÀ / PROXIMITY SWITCHES

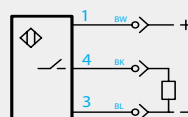
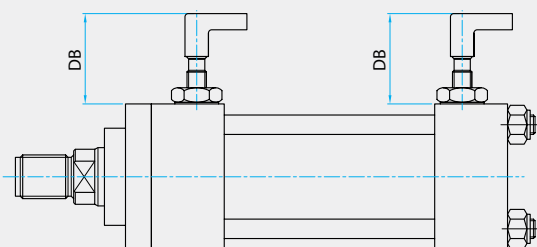

Alesaggio Bore (mm)	DB max (mm)
40	85
50	80
63	80
80	70
100	60
125	65
160	55
200	50

CARATTERISTICHE TECNICHE

SPECIFICATIONS

Temperatura d'esercizio	<i>Working temperature</i>	-25°C ... +80°C
Pressione massima	<i>Maximum pressure</i>	500 bar
Grado di protezione	<i>Protection grade</i>	IP68
Connettore	<i>Connection</i>	S4
Isteresi	<i>Hysteresis</i>	<= 15%
Ripetibilità	<i>Reapeatability</i>	<= 5%
Cablaggio	<i>Wiring</i>	3 fili / 3 wires
Contatto	<i>Switching function</i>	Normalmente aperto / <i>Normally open</i>
Segnale d'uscita	<i>Output signal</i>	PNP
Tensione nominale operativa	<i>Rated operational voltage</i>	24 DCV
Corrente nominale operativa	<i>Rated operationale current</i>	200 mA
Tensione di alimentazione	<i>Supply voltage</i>	10 ... 30 DCV

CODICI DI ORDINAZIONE / ORDERING CODES

SPV	Sensore anteriore / <i>Front sensor</i>
SPZ	Sensore posteriore / <i>Rear sensor</i>
SPK	Sensore anteriore e posteriore / <i>Front and rear sensor</i>

SR (REED)	CARATTERISTICHE TECNICHE / SPECIFICATIONS
<p>BW = marrone / brown BL = blu / blue</p>	Tensione Voltage 24-110 V AC/DC
	Max corrente Max current (a 25 °C) 0.3 A
	Circuito elettrico Electric circuit REED
	Tempo di inserzione Switching-on time 0.8 ms
	Tempo di disinserzione Switching-off time 0.1 ms
	Vita elettrica Electric lifespan 10 ⁷ impulsi / pulse
	Grado di protezione Protection class IP 67 EN60529
	Temperatura ambiente Temperature range -20 +80 °C
	Segnalazione Visual signal LED
	Cavo Cable 2 x 0.25 mm ²
	Lunghezza cavo Cable length 5.0 m

SH (PNP)	CARATTERISTICHE TECNICHE / SPECIFICATIONS
<p>BW = marrone / brown BL = blu / blue BK = nero / black</p>	Tensione Voltage 24 V DC
	Max corrente Max current (a 25 °C) 0.25 A
	Circuito elettrico Electric circuit PNP
	Tempo di inserzione Switching-on time 0.8 ms
	Tempo di disinserzione Switching-off time 0.1 ms
	Vita elettrica Electric lifespan 10 ⁷ impulsi / pulse
	Grado di protezione Protection class IP 67 EN60529
	Temperatura ambiente Temperature range -20 +80 °C
	Segnalazione Visual signal LED
	Cavo Cable 3x0.25 mm ²
	Lunghezza cavo Cable length 5.0 m

USO CORRETTO DEI SENSORI MAGNETICI

I valori di tensione e di corrente non devono mai superare i valori indicati in tabella.
Picchi di corrente possono essere causati da cariche capacitive (es. cavi con lunghezza superiore a 3 m).
Picchi di tensione possono essere causati da induttanze (es. elettrovalvole, relè, teleriduttori, ecc.).
Distorsioni magnetiche possono essere causate da masse ferrose (es. sedi cilindro ricavate all'interno degli stampi) o dalla presenza di forti campi magnetici (es. motori elettrici, bobine, inverter, ecc.).

Per corse inferiori a 20 mm consultare il nostro ufficio tecnico.
In presenza di forti vibrazioni possono verificarsi falsi contatti.

CORRECT USE OF MAGNETIC SENSORS

Voltage and current values must never exceed values specified in the table.
Current surges may be caused by capacitive loads (e.g. cables of lengths over 3 metres).
Voltage surges may be caused by inductance (e.g. solenoid valves, relays, contactors, etc.).
Magnetic distortion may be caused by ferrous masses (e.g. cylinder seat inside moulds) or the presence of strong magnetic fields (e.g. electric motors, coils, inverter etc.).
For strokes lower than 20 mm, contact our technical department
High vibration can generate false contacts.

Alesaggio / Bore	X	Y	Staffa / Bracket
25	43	26	STA
32	45	28	
40	50	32	
50	56	44	STB
63	61	50	
80	71	57	STC
100	78	64	
125	95	80	STD

CODICE ORDINAZIONE SENSORE + STAFFA / SWITCH + BRACKET ORDERING CODE

Tipo Type	Sensore Switch	Staffa / Bracket	Per cilindri di alesaggio / For cylinder with bore
REED	SR	STA	25, 32, 40
PNP	SH	STB	50, 63
		STC	80, 100
		STD	125