

P1D-B Pneumatic ISO Cylinders

P1D-B Basic

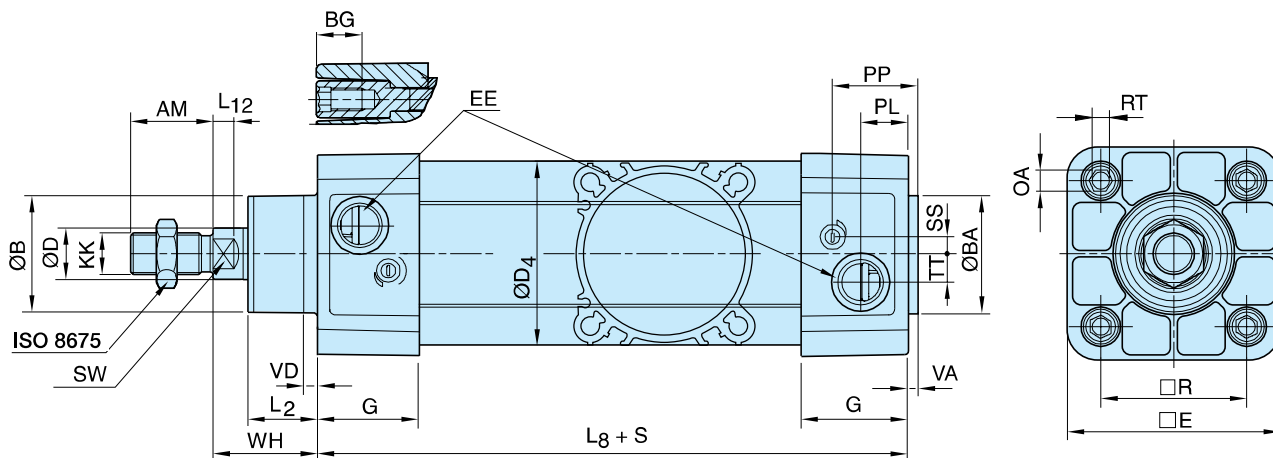

Dimensions (mm)

Cylinder bore mm	AM mm	B mm	BA mm	BG mm	D mm	D4 mm	E mm	EE mm	G mm	KK mm	L2 mm	L8 mm	L12 mm
32	22	30	30	16	12	45,0	48,0	G1/8	28,5	M10x1,25	16,8	94	6,0
40	24	35	35	16	16	52,0	53,5	G1/4	33,0	M12x1,25	19,0	105	6,5
50	32	40	40	16	20	60,7	65,2	G1/4	33,5	M16x1,5	24,0	106	8,0
63	32	45	45	16	20	71,5	75,5	G3/8	39,5	M16x1,5	24,3	121	8,0
80	40	45	45	17	25	86,7	95,0	G3/8	39,5	M20x1,5	30,0	128	10,0
100	40	55	55	17	25	106,7	114,0	G1/2	44,5	M20x1,5	34,0	138	14,0
125	54	60	60	20	32	134,0	139,0	G1/2	51,0	M27x2	45,0	160	18,0

Cylinder bore mm	OA mm	PL mm	PP mm	R mm	RT mm	SS mm	SW mm	TT mm	VA mm	VD mm	WH mm
32	6,0	14,0	24,2	32,5	M6	5,5	10	4,2	3,5	4,5	26
40	6,0	16,0	27,5	38,0	M6	8,0	13	5,5	3,5	4,5	30
50	8,0	14,0	29,3	46,5	M8	9,0	17	7,5	3,5	4,5	37
63	8,0	16,6	30,8	56,5	M8	6,5	17	10,0	3,5	4,5	37
80	6,0	16,8	33,5	72,0	M10	0	22	11,5	3,5	4,5	46
100	6,0	20,5	37,5	89,0	M10	0	22	14,5	3,5	4,5	51
125	8,0	23,3	45,8	110,0	M12	0	27	15,0	5,5	6,5	65

S=Stroke

Tolerances (mm)

Cylinder bore mm	B	BA	L ₈ mm	L ₉ mm	R mm	Stroke tolerance up to stroke 500 mm	Stroke tolerance for stroke over 500 mm
32	d11	d11	±0,4	±2	±0,5	+0,3/+2,0	+0,3/+3,0
40	d11	d11	±0,7	±2	±0,5	+0,3/+2,0	+0,3/+3,0
50	d11	d11	±0,7	±2	±0,6	+0,3/+2,0	+0,3/+3,0
63	d11	d11	±0,8	±2	±0,7	+0,3/+2,0	+0,3/+3,0
80	d11	d11	±0,8	±3	±0,7	+0,3/+2,0	+0,3/+3,0
100	d11	d11	±1,0	±3	±0,7	+0,3/+2,0	+0,3/+3,0
125	d11	d11	±1,0	±3	±1,1	+0,3/+2,0	+0,3/+3,0