

High performance miniature circular connectors

HR10 Series

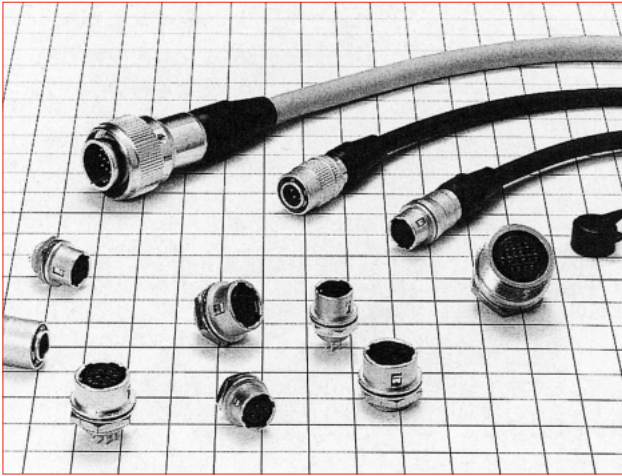

■ Features

1. A simple, yet highly reliable design for compact, high density applications

Although small in size, the HR10 series are full featured connectors with a well integrated design.

2. Extremely easy mating/unmating operations

Easy to operate, the single-action push-pull lock structure allows for quick and efficient locking and unlocking.

■ Product Specifications

Ratings	Shell size	No. of contacts	Rated current
	7	4	2A
		5	
		6	
10	10 12	2A	
13	20	2A	

Ratings	Shell size	No. of contacts	Rated voltage
	7	4	AC150V, DC200V AC100V, DC140V AC100V, DC140V
		5	
		6	
10	10 12	AC100V, DC140V	
13	20	AC100V, DC140V	

Ratings	Operation temperature range	-25 to +85°C
	Storage temperature range	-10 to +60°C

Items	Specifications	Conditions
1. Contact resistance	10mΩ min.	Measured at DC 1A
2. Insulation resistance	1,000MΩ min.	Measured at DC 100V
3. Withstanding voltage	No flashover or dielectric breakdown.	AC 300V for one minute, 4 contacts : AC 500V for one minute
4. Vibration resistance	No electrical discontinuity of 10μs or greater	10 to 55 Hz/cycle, amplitude : 0.75mm, 3 axis directions, for 2 hours each
5. Shock resistance	No electrical discontinuity of 10μs or greater	Acceleration : 490m/s ² , duration : 11ms 3 directions, 3 times each
6. Mating Cycles	Contact resistance : 15mΩ min.	1,000 times
7. Temperature cycle	Insulation resistance : 1,000MΩ min.	-55°C : 30minutes→Normal temperature : 10 to 15 minutes→ 85°C : 30minutes→Normal temperature : 10 to 15minutes, left for 5 cycles.
8. Humidity resistance	5MΩ min. (at high humidity) 50MΩ min. (at dry)	Temperature : 40°C, relative humidity : 90 to 95%, left for 96 hours

Materials / Finish

Items	Material	Finish	Remarks
Exterior	Zinc alloy, brass	Matte finished nickel plating	—————
Insulator	Polyamide resin, PBT resin	—————	Blue, Black
Contact	Copper alloy	HR10 : Gold plating HR10A : Silver plating	—————

Product Number Structure

Refer to the chart below when determining the product specifications from the product number.
Please select from the product numbers listed in this catalog when placing orders.

HR10A - 7 P - 3 P C ()**

①
②
③
④
⑤
⑥
⑦

<p>① Model name : Indicates the HR10A Series. The part type is identified as follows. HR10A : Lower cost type HR10G : Shield type HR10B : Coaxial contact type</p>
<p>② Shell size : The shell size is the outer shell diameter or the mating interface end of the plug.</p>
<p>③ Shell type P : Plug R : Receptacle J : Jack</p>
<p>④ Number of contacts</p>
<p>⑤ Contact form P : Male contact S : Female contact</p>
<p>⑥ Contact termination method: None : Solder termination C : Crimp termination</p>
<p>⑦ Other specifications : A two-digit character is added to indicate other specifications as needed.</p>

◆ Diagrams of Connectors in Combination

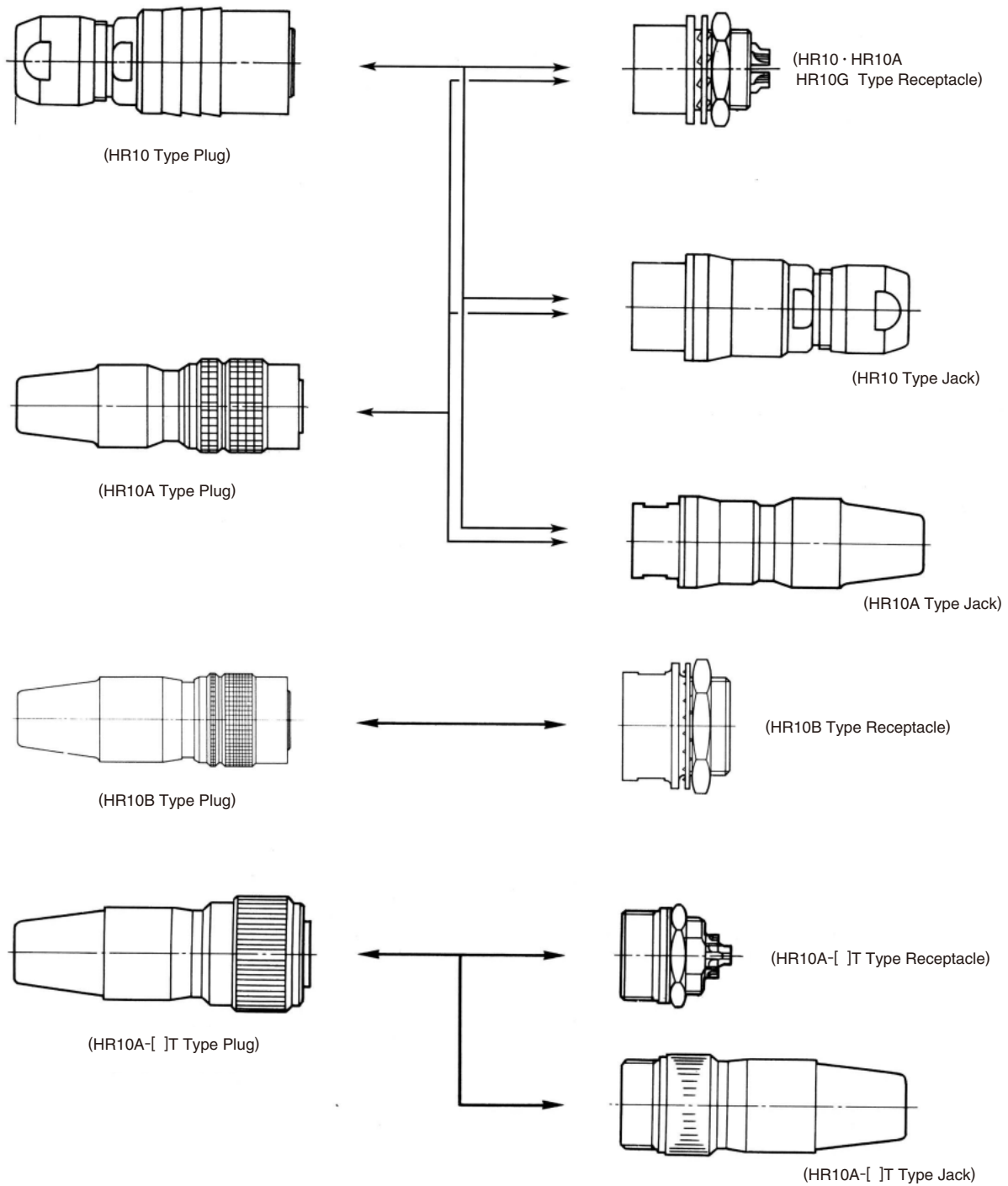

Notes

- 1 : When using a plug with male terminal, be sure to use a receptacle or jack fitted with female terminal.
- 2 : Standard finish of the terminal is gold plating for the HR10, and silver plating for the HR10A and HR10G.
Be sure to use male and female connectors of the same plating.

■ HR10 type

HR10 type connectors, use a gold plated contact as the standard plating specification. Silver plating is used on the contacts for other series such as HR10A and HR10G. To avoid mixing gold and silver contacts, please be sure to confirm the plating specification when using HR10 type connectors with HR10A or HR10G connectors.

● Plug

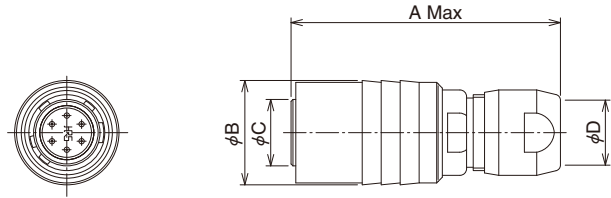

(Representative example)

Unit : mm

Part No.	HRS No.	No. of Contacts	A	φB	φC	φD	Weight
HR10-7P-4P(73)	110-0021-6 73	4	28.5	11	7	5.2	8g
HR10-7P-4S(73)	110-0022-9 73						
HR10-7P-6P(73)	110-0023-1 73	6	28.5	11	7	5.2	8g
HR10-7P-6S(73)	110-0024-4 73						
HR10-10P-12P(73)	110-0025-7 73	12	32.5	14	9.5	7.2	15g
HR10-10P-12S(73)	110-0026-0 73						

● Receptacle

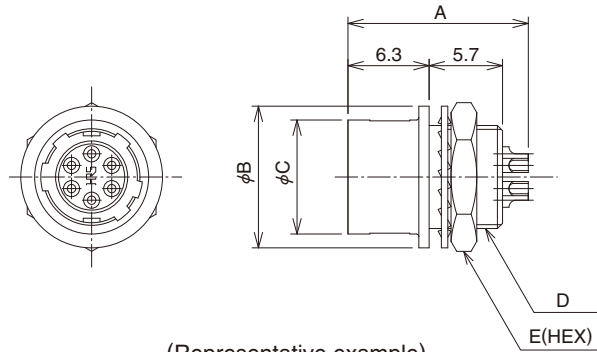

(Representative example)

Unit : mm

Part No.	HRS No.	No. of Contacts	A	φB	φC	D	E	Weight
HR10-7R-4S(73)	110-0031-0 73	4	14	11	8.85	M8×0.5	10	3.5g
HR10-7R-4P(73)	110-0032-2 73							
HR10-7R-6S(73)	110-0033-5 73	6	14	11	8.85	M8×0.5	10	3.5g
HR10-7R-6P(73)	110-0034-8 73							
HR10-10R-12S(73)	110-0035-0 73	12	16	14	11.9	M11×0.75	13	6g
HR10-10R-12P(73)	110-0036-3 73							

Remarks : For mounting holes, see page 20.

● Receptacle (PCB dip type)

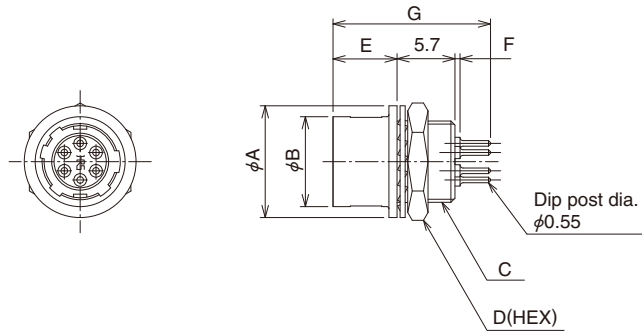

(Representative example)

Unit : mm

Part No.	HRS No.	No. of Contacts	φA	φB	C	D	E	F	G	Weight
HR10-7R-4SA(73)	110-0059-9 73	4	11	8.85	M8×0.5	10	6.3	0.5	15.5	3g
HR10-7R-6SA(73)	110-0050-4 73	6								
HR10-7R-6PA(73)	110-0061-0 73	12	14	11.9	M11×0.75	13				5g
HR10-10R-12SA(73)	110-0049-5 73									
HR10-10R-12PA(73)	110-0055-8 73									

Remarks : 1. For mounting holes, see page 20.
2. For dip post arrangement, see page 16.

● Jack

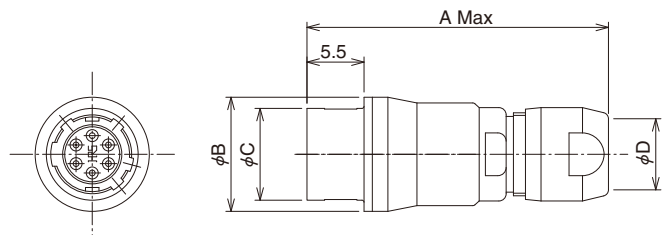

(Representative example)

Unit : mm

Part No.	HRS No.	No. of Contacts	A	φB	φC	φD	Weight
HR10-7J-4S(73)	110-0027-2 73	4	28.5	11	8.85	5.2	7g
HR10-7J-4P(73)	110-0028-5 73						
HR10-7J-6S(73)	110-0029-8 73	6	32.5	14	11.9	7.2	14g
HR10-7J-6P(73)	110-0030-7 73						
HR10-10J-12S(73)	110-0037-6 73	12	32.5	14	11.9	7.2	14g
HR10-10J-12P(73)	110-0038-9 73						

■ HR10A·10G Types

HR10A connectors are a lower-cost version, yet still provide a high "Value Add" while preserving the superior characteristics of the HR10 connectors. Cable clamps are crimped using a special crimping tool, and the shells have a rubber boot which provides a flexible design that helps to prevent cable twisting.

The HR10G connector is a shielded type connector which has an internal contacting structure between the plug shell and receptacle shell.

Contacts in both HR10A and 10G connectors are silver plated as standard.

● Plug (Solder type)

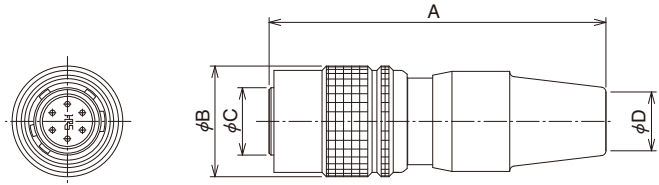

(Representative example)

Unit : mm

Part No.	HRS No.	No. of Contacts	A	φB	φC	φD	Weight
HR10A-7P-4P(73)	110-0301-2 73	4	35	11.5	7	5	9g
HR10A-7P-4S(73)	110-0302-5 73						
HR10A-7P-5P(73)	110-0318-5 73	5					
HR10A-7P-5S(73)	110-0319-8 73						
HR10A-7P-6P(73)	110-0303-8 73	6					
HR10A-7P-6S(73)	110-0304-0 73						
HR10A-10P-10P(73)	110-0407-3 73	10	43	14.7	9.5	7	16g
HR10A-10P-10S(73)	110-0408-6 73						
HR10A-10P-12P(73)	110-0401-7 73	12					
HR10A-10P-12S(73)	110-0402-0 73						
HR10A-13P-20P(73)	110-0713-0 73	20	59	19	13	37g	
HR10A-13P-20S(73)	110-0716-8 73						

● Plug(Crimp type)

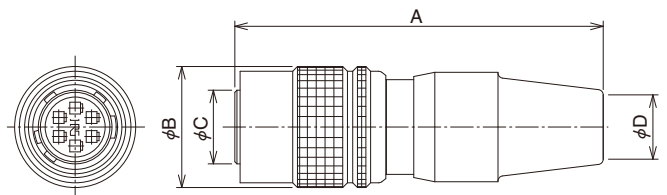

(Representative example)

Unit : mm

Part No.	HRS No.	No. of Contacts	A	φB	φC	φD	Weight					
HR10A-7P-4PC(73)	110-0501-1 73	4	35	11.5	7	5	9g					
HR10A-7P-4SC(73)	110-0502-4 73											
HR10A-7P-6PC(73)	110-0503-7 73	6										
HR10A-7P-6SC(73)	110-0504-0 73											
HR10A-10P-10PC(73)	110-0601-6 73	10						43	14.7	9.5	7	16g
HR10A-10P-10SC(73)	110-0602-9 73											
HR10A-10P-12PC(73)	110-0603-1 73	12										
HR10A-10P-12SC(73)	110-0604-4 73											
HR10A-13P-20PC(73)	110-0701-0 73	20	59	19	13	37g						
HR10A-13P-20SC(73)	110-0702-3 73											

●Receptacle (Solder type)

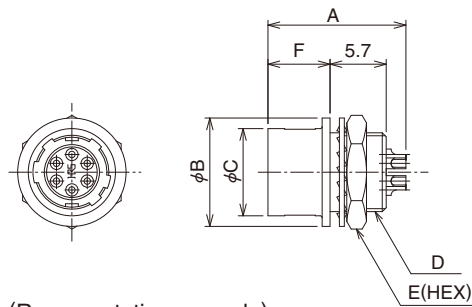

(Representative example)

Unit : mm

Part No.	HRS No.	No. of Contacts	A	φB	φC	D	E	E	Weight	Remarks
HR10A-7R-4S(73)	110-0305-3 73	4	14	11	8.85	M8×0.5	10	6.3	3g	
HR10A-7R-4P(73)	110-0306-6 73									
HR10A-7R-5S(73)	110-0320-7 73	5	14	11	8.85	M8×0.5	10	6.3	3g	
HR10A-7R-5P(73)	110-0321-0 73									
HR10A-7R-6S(73)	110-0307-9 73	6	14	11	8.85	M8×0.5	10	6.3	3g	
HR10A-7R-6P(73)	110-0308-1 73									
HR10A-10R-10S(71)	110-0409-9 71	10	16	14	11.9	M11×0.75	13	6.3	5g	
HR10A-10R-10P(73)	110-0410-8 73									
HR10A-10R-12S(71)	110-0403-2 71	12	16	14	11.9	M11×0.75	13	6.3	5g	
HR10A-10R-12P(73)	110-0404-5 73									
HR10A-13R-20S(73)	110-0714-2 73	20	19.2 20.2	18	15.4	M14×0.75	17	9.3	8g	
HR10A-13R-20P(73)	110-0715-5 73									
HR10G-7R-4S(73)	110-1601-1 73	4	14	11	8.85	M8×0.5	10	6.3	3g	Shield type
HR10G-7R-4P(73)	110-1602-4 73									
HR10G-7R-6S(73)	110-1605-2 73	6	14	11	8.85	M8×0.5	10	6.3	3g	Shield type
HR10G-7R-6P(73)	110-1606-5 73									
HR10G-10R-10S(71)	110-1607-8 71	10	16	14	11.9	M11×0.75	13	6.3	5g	Shield type
HR10G-10R-10P(73)	110-1608-0 73									
HR10G-10R-12S(71)	110-1609-3 71	12	16	14	11.9	M11×0.75	13	6.3	5g	Shield type
HR10G-10R-12P(73)	110-1610-2 73									

Remarks : For mounting holes, see page 20.

●Receptacle (Crimp type)

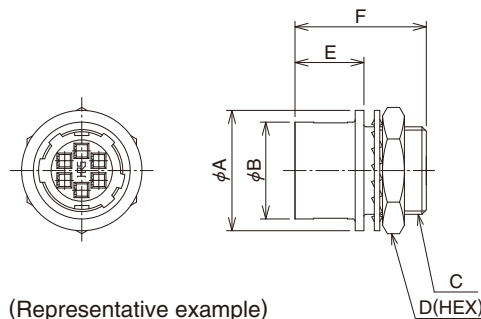

(Representative example)

Unit : mm

Part No.	HRS No.	No. of Contacts	φA	φB	C	D	E	F	Weight	Remarks
HR10A-7R-4SC(73)	110-0506-5 73	4	11	8.85	M8×0.5	10	6.3	12	3g	
HR10A-7R-4PC(73)	110-0505-2 73							12.2		
HR10A-7R-6SC(73)	110-0508-0 73	6	14	11.9	M11×0.75	13	6.3	12	5g	
HR10A-7R-6PC(73)	110-0507-8 73							12.2		
HR10A-10R-10SC(71)	110-0606-0 71	10	14	11.9	M11×0.75	13	6.3	12	5g	
HR10A-10R-10PC(71)	110-0605-7 71							12.2		
HR10A-10R-12SC(71)	110-0608-5 71	12	14	11.9	M11×0.75	13	6.3	12	5g	
HR10A-10R-12PC(71)	110-0607-2 71							12.2		
HR10A-13R-20SC(73)	110-0703-6 73	20	18	15.4	M14×0.75	17	9.3	15	8g	
HR10A-13R-20PC(73)	110-0704-9 73							15		
HR10G-7R-4SC(73)	110-1701-6 73	4	11	8.85	M8×0.5	10	6.3	12	3g	Shield type
HR10G-7R-4PC(73)	110-1702-9 73							12.2		
HR10G-7R-6SC(73)	110-1705-7 73	6	14	11.9	M11×0.75	13	6.3	12	5g	Shield type
HR10G-7R-6PC(73)	110-1706-0 73							12.2		
HR10G-10R-10SC(71)	110-1707-2 71	10	14	11.9	M11×0.75	13	6.3	12	5g	Shield type
HR10G-10R-10PC(71)	110-1708-5 71							12.2		
HR10G-10R-12SC(71)	110-1709-8 71	12	14	11.9	M11×0.75	13	6.3	12	5g	Shield type
HR10G-10R-12PC(71)	110-1710-7 71							12.2		
HR10G-13R-20SC(73)	110-1711-0 73	20	18	15.4	M14×0.75	17	9.3	15	8g	
HR10G-13R-20PC(73)	110-1712-2 73							15		

Remarks : For mounting holes, see page 20.

● Receptacle (Dip type)

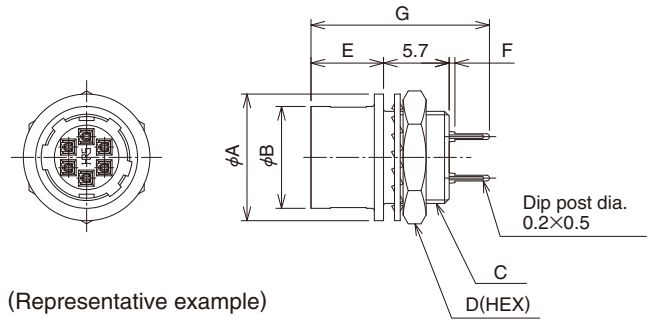

Unit : mm

Part No.	HRS No.	No. of Contacts	φA	φB	C	D	E	F	G	Weight	Remarks
HR10A-7R-4SB(73)	110-0314-4 73	4	11	8.85	M8x0.5	10	6.3	0.5	15.6	3g	
HR10A-7R-4PB(73)	110-0315-7 73										
HR10A-7R-5SB(73)	110-0322-2 73	5	11	8.85	M8x0.5	10	6.3	0.5	15.6	3g	
HR10A-7R-6SB(73)	110-0316-0 73										
HR10A-7R-6PB(73)	110-0317-2 73	6	11	8.85	M8x0.5	10	6.3	0.5	15.6	3g	
HR10A-10R-10SB(71)	110-0413-6 71										
HR10A-10R-10PB(71)	110-0414-9 71	10	14	11.9	M11x0.75	13	6.3	0.5	15.6	5g	
HR10A-10R-12SB(71)	110-0415-1 71										
HR10A-10R-12PB(71)	110-0416-4 71	12	14	11.9	M11x0.75	13	6.3	0.5	15.6	5g	
HR10A-13R-20SB(73)	110-0707-7 73										
HR10A-13R-20PB(73)	110-0708-0 73	20	18	15.4	M14x0.75	17	9.3	0	17.8	8g	
HR10G-7R-4SB(73)	110-1801-0 73										
HR10G-7R-4PB(73)	110-1802-3 73	4	11	8.85	M8x0.5	10	6.3	0.5	15.6	3g	
HR10G-7R-6SB(73)	110-1805-1 73										
HR10G-7R-6PB(73)	110-1806-4 73	6	11	8.85	M8x0.5	10	6.3	0.5	15.6	3g	
HR10G-10R-10SB(71)	110-1807-7 71										
HR10G-10R-10PB(71)	110-1808-0 71	10	14	11.9	M11x0.75	13	6.3	0.5	15.6	5g	Shield type
HR10G-10R-12SB(71)	110-1809-2 71										
HR10G-10R-12PB(71)	110-1810-1 71	12	14	11.9	M11x0.75	13	6.3	0.5	15.6	5g	Shield type
HR10G-13R-20SB(73)	110-1811-4 73										
HR10G-13R-20PB(73)	110-1812-7 73	20	18	15.4	M14x0.75	17	9.3	0	17.8	8g	

Remarks : 1. For mounting holes, see page 20.
2. For dip post arrangement, see page 16.

● Dust cap

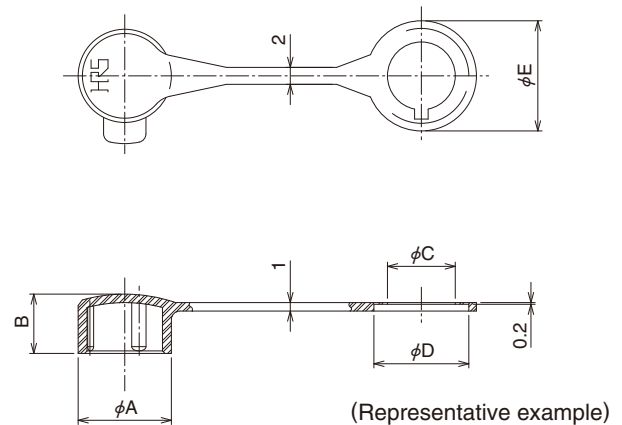
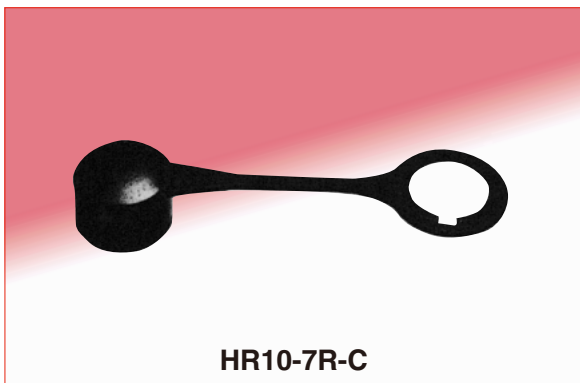

Unit : mm

Part No.	HRS No.	φA	B	φC	φD	φE
HR10-7R-C	110-0058-6 00	11	7	8	11.2	13
HR10-10R-C	110-0052-0 00	14	8.5	10.8	14.1	15
HR10A-13R-C	110-0452-8 00	17.5	11.5	14	18.1	19

● Jack (Solder type)

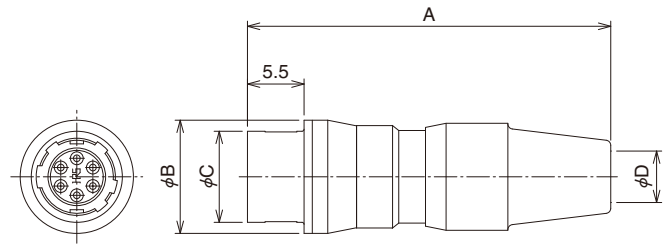

(Representative example)

Unit : mm

Part No.	HRS No.	No. of Contacts	A	φB	φC	φD	Weight					
HR10A-7J-4S(73)	110-0309-4 73	4	35.3	11	8.85	5	9g					
HR10A-7J-4P(73)	110-0310-3 73											
HR10A-7J-6S(73)	110-0311-6 73	6										
HR10A-7J-6P(73)	110-0312-9 73											
HR10A-10J-10S(73)	110-0411-0 73	10						43.5	14	11.9	7	16g
HR10A-10J-10P(73)	110-0412-3 73											
HR10A-10J-12S(73)	110-0405-8 73	12										
HR10A-10J-12P(73)	110-0406-0 73											

● Jack (Crimp type)

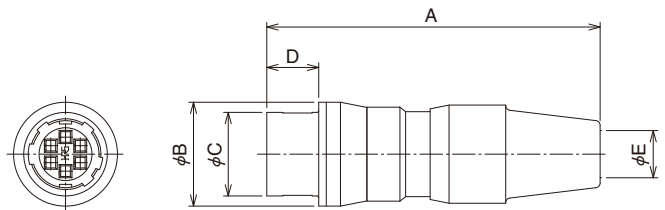

(Representative example)

Unit : mm

Part No.	HRS No.	No. of Contacts	A	φB	φC	D	φE	Weight
HR10A-7J-4SC(73)	110-0510-2 73	4	35.3	11	8.85	5.5	5	9g
HR10A-7J-6SC(73)	110-0512-8 73	6						
HR10A-10J-10SC(73)	110-0610-7 73	10	43.5	14	11.9		7	16g
HR10A-10J-12SC(73)	110-0612-2 73	12						
HR10A-13J-20SC(73)	110-0705-1 73	20	58.5	18	15.4	8.5		37g
HR10A-13J-20PC(73)	110-0706-4 73							

■ HR10B Type Connector

The HR10B connector combines 10 signal lines and one coaxial contact in the standard number 10 shell. Performance specifications for the coaxial contacts are on the 11 page.

● Plug

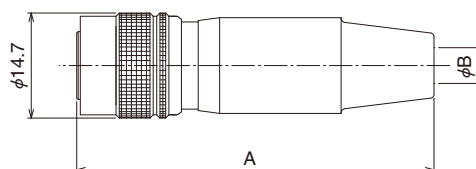

(Representative example)

Unit : mm

Part No.	HRS No.	A	φB	Applicable coaxial contact
HR10B-10P-10PC(73)	110-0901-0 73	50	5	HR10B-2.5CJ(73)
HR10B-10PA-10PC(73)	110-0906-3 73	43	7	

● Receptacle

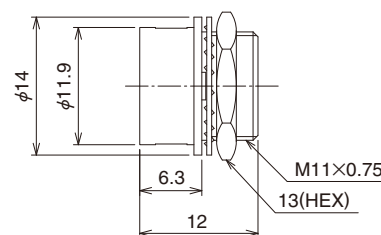
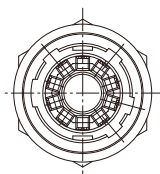

(Representative example)

Unit : mm

Part No.	HRS No.	Applicable coaxial contact
HR10B-10R-10SC(71)	110-0902-2 71	HR10B-2.5CP(73)

Remarks : For mounting holes, see page 20.

Coaxial contacts

The coaxial contacts shown here are for use with the HR10B connector. These contacts have locking barbs and are inserted from the rear of connector. Please use the following information to select the correct terminals.

Materials / Finish

Part	Material	Finish
Plug shell	Brass	Gold plating
Jack shell		
Insulator	Tetrafluoride resin	
Male pin	Phosphor bronze	Gold plating
Female pin	Beryllium copper	

Performance

Description	Test data
Impedance	50Ω
Insulation resistance	1000MΩ or more at DC250V
Contact resistance	Center 6.5mΩ or less and outer 4mΩ or less at DC1A
Withstanding voltage	AC250V r.m.s for 1minute
V.S.W.R	1.3 or less for 0 to 1000MHz
Pull force	4.9N (500gf) or more

● Plug

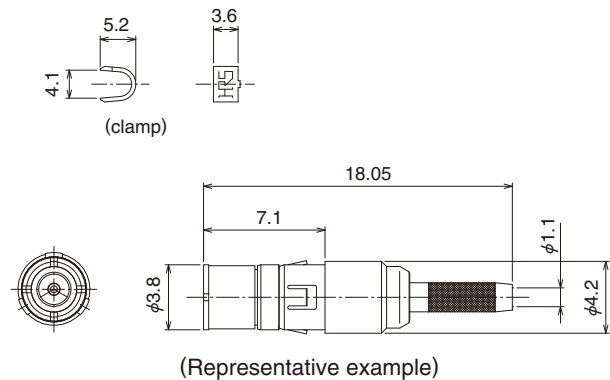

Unit : mm

Part No.	HRS No.	Applicable cable	Applicable connector
HR10B-2.5CP(73)	110-0904-8 73	0.8D-QEW-CW(By Fjikura wire)	HR10B-10R-10SC(71)

● Jack

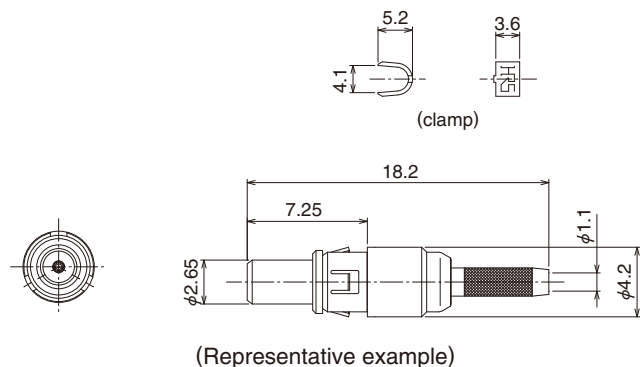

Unit : mm

Part No.	HRS No.	Applicable cable	Applicable connector
HR10B-2.5CJ(73)	110-0903-5 73	0.8D-QEW-CW(By Fjikura wire)	HR10B-10P-10PC(73)

◆ Cable connecting methods

HR10B-2.5CP(73)

HR10B-2.5CJ(73)

1. Cable end treatment

Fig.1

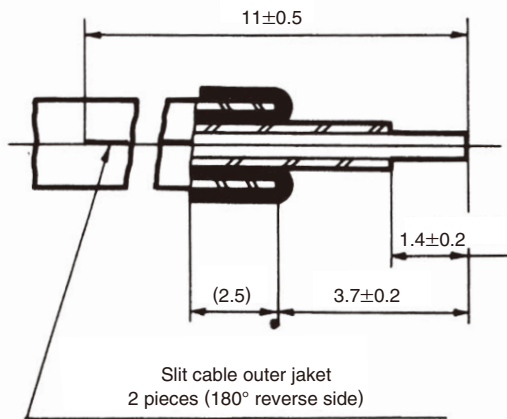

1. Dimensions for cable end treatment are shown in Fig 1.

2. Termination is described below.

- (1) Strip cable outer jacket as indicated.
- (2) Slit outer jacket on both sides per Fig.1.
- (3) Fold back outer cover.
- (4) Remove insulator from cable.

2. Soldering male pin to cable center conductor

Fig.2

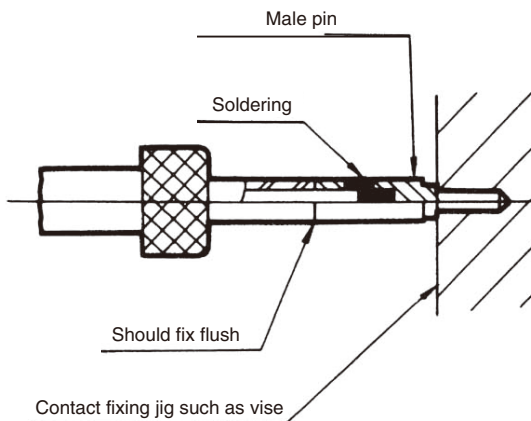

1. Solder male pin to cable center conductor as indicated in Fig.2.

- (1) Pre-solder the solder pot of pin with $\phi 0.5$ mm string solder.
- (2) Male pin should fit flush against the cable insulator as shown.
- (3) Remove any excess solder from the pin with a knife. This surface must be smooth.
- (4) A properly soldered terminal will yield 500gf when stretched.

3. Crimping cable outer conductor

Fig.3

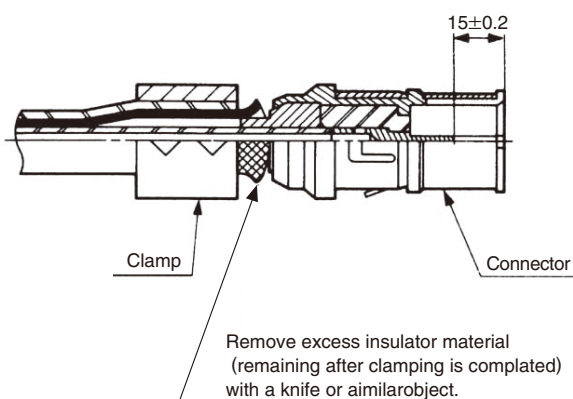

1. Insert the cable into the connector and make sure to push it all the way in. To confirm that the cable is fully inserted, make sure that the depth is 1.5 ± 0.2 mm by measuring from the end of the connector to the tip of the male contact by using a vernier calipers or other suitable measuring device.

2. Use the HR10-TC-01 tool to crimp the metal fitting to the cable.

■ HR10A-()T Type (Threaded Coupling Type)

HR10A-()T connector is a new product having a threaded coupling locking mechanism. Electric performance is same as HR10 and HR10A push-pull locking type connectors.

● Plug (Solder type)

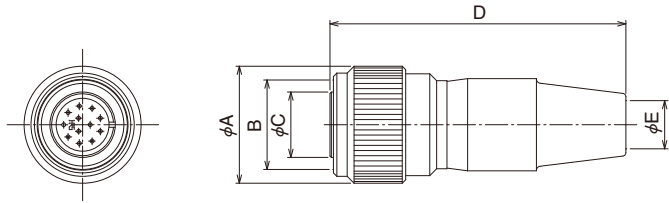

(Representative example)

Unit : mm

Part No.	HRS No.	No. of Contacts	φA	B	φC	D	φE	Remarks
HR10A-7TP-6P(73)	110-0331-3 73	6	12	M10×0.75	7	35	5	Gold plating
HR10A-7TP-6P(74)	110-0331-3 74							
HR10A-10TP-12P(73)	110-0432-0 73	12	17	M13×0.75	9.5	43	7	
HR10A-10TPA-12S(73)	110-0446-5 73							
HR10A-10WTP-12P(73)	110-1101-9 73		15	M12×0.75	45.8	6.5	*	
HR10A-10WTP-12S(73)	110-1106-2 73							
HR10A-13TPD-20P(73)	110-1015-9 73	20	20	M17×1	13	56.5	7	

*Waterproof plug need resin filling inside when connector assembly.
When mated, the connector against water penetration.

● Plug (Crimp type)

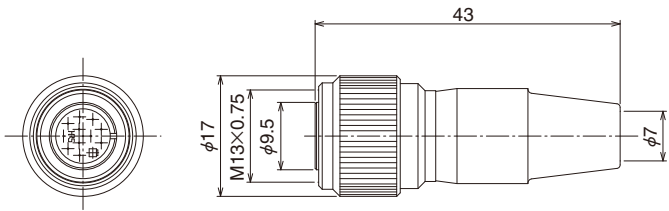

(Representative example)

Unit : mm

Part No.	HRS No.	No. of Contacts
HR10A-10TP-12PC(73)	110-0455-6 73	12

●Receptacle (Solder type)

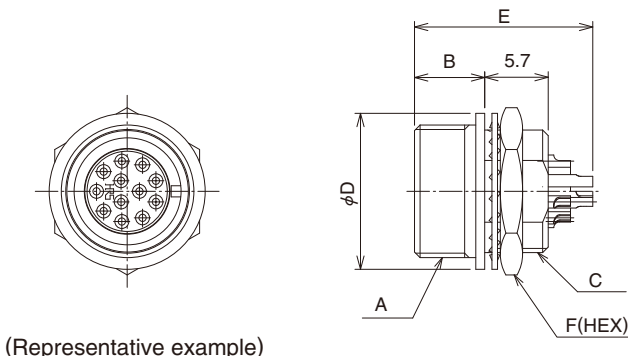

Unit : mm

Part No.	HRS No.	No. of Contacts	A	B	C	φD	E	F	Remarks
HR10-7TR-6S(73)	110-0089-0 73	6	M10×0.75	6.3	M8×0.5	11	14	10	Gold plating
HR10A-10TR-12S(73)	110-0453-0 73	12	M13×0.75		M11×0.75	14	16	13	
HR10A-10WTR-12S(73)	110-1104-7 73		M12×0.75	M10.5×0.75					

Remarks : For mounting hole, see page 15(10TR,10WTR) 20(7TR).

●Receptacle (Crimp type)

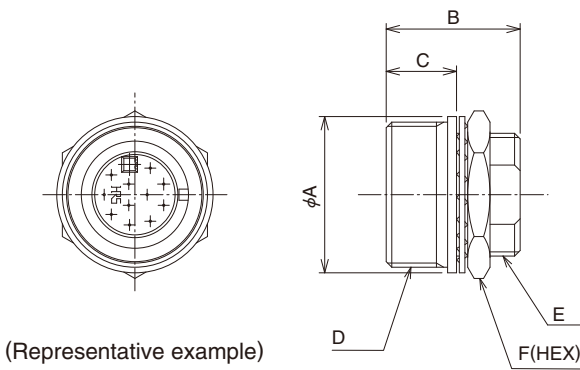

Unit : mm

Part No.	HRS No.	No. of Contacts	φA	B	C	D	E	F
HR10A-10TR-12SC(73)	110-0456-9 73	12	14	12	6.3	M13×0.75	M11×0.75	13
HR10A-13TR-20SC(73)	110-1002-7 73	20	18	15	9.3	M17×1	M14×0.75	17

Remarks : For mounting hole, see page 15

●Receptacle (Dip type)

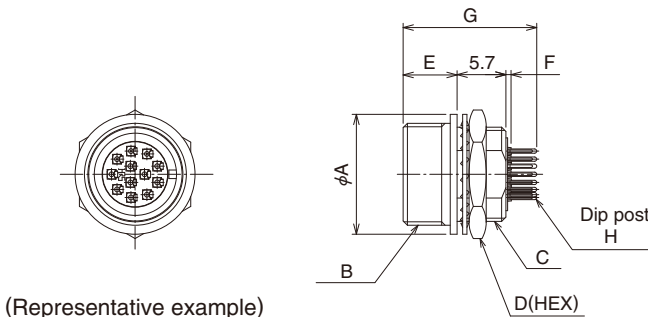

Unit : mm

Part No.	HRS No.	No. of Contacts	φA	B	C	D	E	F	G	H
HR10A-7TR-6SA(73)	110-0330-0 73	6	11	M10×0.75	M8×0.5	10			15.5	φ0.55
HR10A-10TR-12SB(73)	110-0433-3 73	12	14	M13×0.75	M11×0.75	13	6.3	0.5	15.6	0.2×0.5
HR10A-10TR-12PB(73)	110-0457-1 73								15.5	
HR10A-10TR-12PE(73)	110-0445-2 73								14	
HR10A-10WTR-12SB(73)	110-1102-1 73								15.6	
HR10A-13TR-20SB(73)	110-1014-6 73								17.8	
		20	18	M17×1	M14×0.75	17	9.3	0	17.8	

Remarks : 1.For mounting holes, see page 15. However, 7TR size shell be referred to page 20 on the shell size 7.
2.For dip post arrangement, see page 16.

● Jack (Solder type)

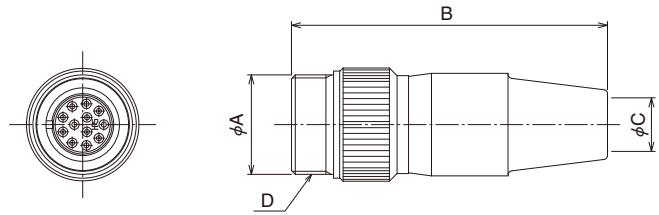

(Representative example)

Unit : mm

Part No.	HRS No.	No. of Contacts	ϕA	B	ϕC	D	Remarks
HR10A-10TJ-12S(73)	110-0436-1 73	12	14.7	41.3	7	M13x0.75	
HR10A-10TJ-12P(73)	110-0459-7 73						
HR10A-10WTJ-12S(73)	110-1103-4 73		14	46.5	6.5	M12x0.75	*

*Waterproof jack need resin filling inside when connector assembly.
When mated, the connector against water penetration.

◆ Panel mounting hole dimensions (Screw coupling)

The mounting hole dimensions shown below are for connectors to be tightened by a hexagonal nut from the back of the panel. The dimensions below apply only to the HR10A-()T and not the 7TR. For the dimensions of connectors of other types, see page 20.

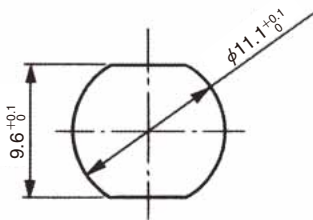

Type HR10A-10TR
(Panel thickness 1 to 2mm)

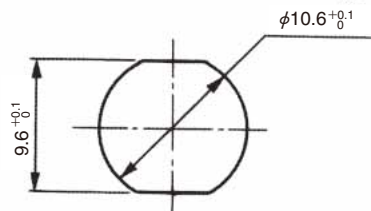

Type HR10A-10WTR
(Panel thickness 1 to 2mm)

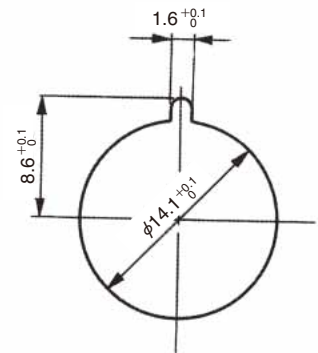

Type HR10A-13TR
(Panel thickness 1 to 1.5mm)

◆ Contact

● Male contact

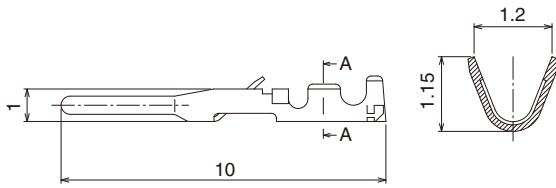

Unit : mm

Type	Part No.	HRS No.	Type of plating	Applicable cable
Loose contact	HR10-PC-111	110-0515 6	Partial gold plating	26 to 30 AWG
	HR10-PC-112	110-0513 0	Silver plating	
Reel contact	HR10-PC-211	110-0516 9	Partial gold plating	
	HR10-PC-212	110-0514 3	Silver plating	

Remarks : 1. Use cables with a coating outside diameter of 1mm or less.
2. Loose piece terminal are available in packs. Each pack contains 100 terminals. Strip terminals are available in reels. Each reel contains 10,000 terminals.

● Female contact

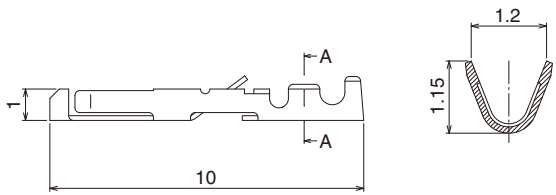

Unit : mm

Type	Part No.	HRS No.	Type of plating	Applicable cable
Loose contact	HR12-SC-111	112-0410 0	Partial gold plating	26 to 30 AWG
	HR12-SC-112	112-0411 3	Silver plating	
Reel contact	HR12-SC-211	112-0407 6	Partial gold plating	
	HR12-SC-212	112-0408 9	Silver plating	

Remarks : 1. Use cables with a coating outside diameter of 1mm or less.
2. Loose piece terminal are available in packs. Each pack contains 100 terminals. Strip terminals are available in reels. Each reel contains 10,000 terminals.

◆ Receptacle dip post arrangement dimensions

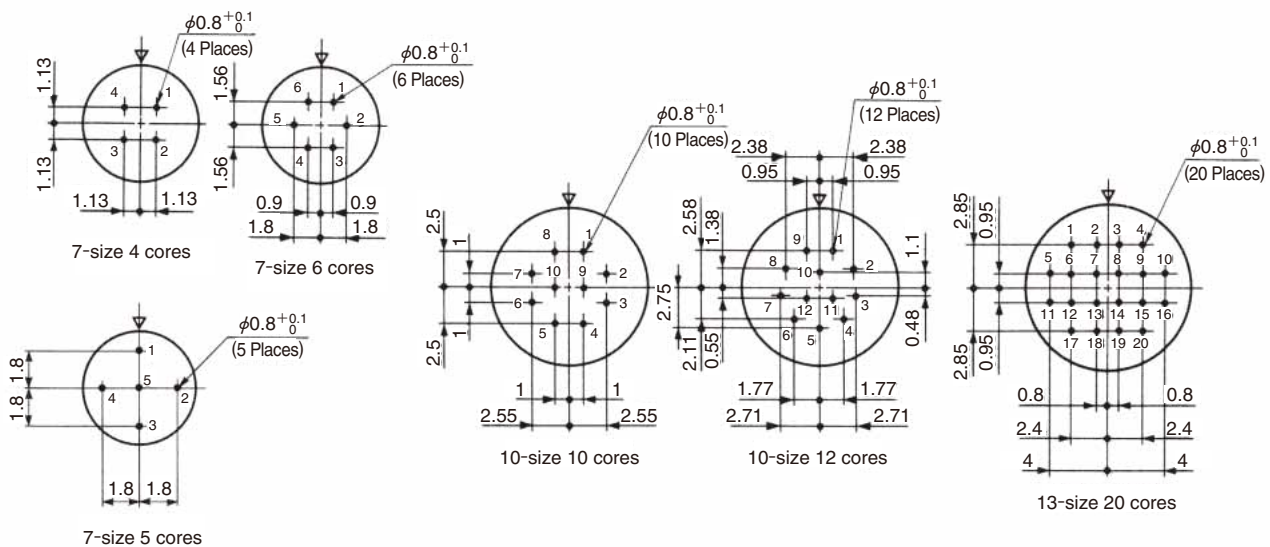

Remarks : 1. The above figures are views from the mating side and pin inserts from the wiring-connection side.
2. Dimensional tolerance of ± 0.05 is recommended for the board arrangement.

◆ **Tools**

Type	Item	Part No.	HRS No.	Applicable terminal	Applicable cable
Manual	Manual crimping tool	HT802/HR12-SC-1	150-0400-3	HR10-PC-112	26 to 30AWG
				HR12-SC-112	
Automatic	Automatic crimping machine body	CM-105C	901-0001-0	—————	—————
	Applicator	AP105-HR12-1	901-2015-9	HR10-PC-211 212 HR12-SC-211 212	26 to 30AWG
Cable crimping tool		HR10-TC-01	150-0036-2	—————	(HR10B-2.5CP(73), HR10B-2.5CJ(73))
		HR10A-TC-02	150-0041-2		$\phi 5, \phi 7$
Extractor		HR12-SC-TP	150-0050-3	HR12-SC-112 HR12-SC-212	—————
		RP6-SC-TP	150-0039-0	HR10-PC-112 HR10-PC-212	
		HR10B-TP	150-0061-0	HR10B-2.5CP(73) HR10B-2.5CJ(73)	



(HT802/HR12-SC-1)
Hand Crimp Tool



(HR12-SC-TP)

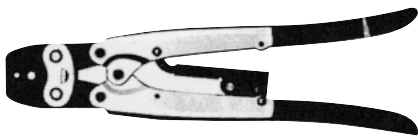

(HR10A-TC-02)
Hand Cable Crimp Tool



(RP6-SC-TP)
Extraction Tool



Auto Crimp Tool CM-105C

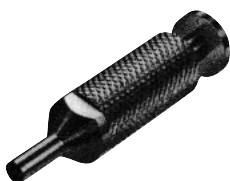

(HR10B-TP)
Coaxial Contact Removal Tool

◆ How to use a connector

	1.Inserting	2.Withdrawing
HR10 TYPE		
HR10A TYPE		
	<p>Hold the plug at point A, align the plug guide with the receptacle guide, and push the plug straight. The plug will mate with the receptacle smoothly.</p>	<p>Hold the plug connection sleeve B and pull the sleeve straight. The plug will come off easily.</p>

◆ Connecting tools

When terminating the wires, use the jigs noted below for easy assembly / disassembly of the connector parts.



Part No.	HRS No.	Applicable connector
HR10-7P-T01	150-0009-0	HR10-7P
HR10-10P-T02	150-0010-9	HR10-10P
HR10-7J-T03	150-0011-1	HR10-7J
HR10-10J-T04	150-0012-4	HR10-10J
HR10-13P-T05	150-0059-8	HR10-13P
HR10-13J-T06	150-0060-7	HR10-13J

◆ Cable assembly procedure on plug side

This applies also to the jack side assembly procedure.

No special procedure is given here for the receptacle side because no special procedure is necessary.

Size	HR10	HR10A
7	8	7.5
10	11	9.5
13	—	13

Size	Dimension C for HR10	Dimension D for HR10A	
		Solder type	Crimp type
7	5.5 or less	10	15 to 20
10	7 or less	16	
13	—	25	

Size	Tightening force
7	1.5N·m(15kg·cm)
10	2N·m(20kg·cm)
13	

	HR10 TYPE	HR10A TYPE
1	Use cables with a nominal sectional area of 0.129mm ² (26 AWG) at the finish outside diameters applicable for each size.	
2	After processing the cable ends according to the dimensions in the above drawings, fit the parts to the cable as shown in the drawings.	
	Fit the parts to the cable in the following order: tightener, clamp washer, and plug body.	Fit the parts to the cable in the following order: cord bushing and plug body.
3	(solder type) Insert the P shell unit into the assembly tool stand and solder it.	
	(crimp type) After crimping the appropriate crimp terminal to the cable core, insert the crimp terminal into the terminal hole in the P shell unit.	
4	Assemble the connector in the following steps. 1. Screw the plug body into the thread in the P shell unit with the tightening force shown in Table 1 using a torque wrench with a fixed torque. Before tightening the plug body, slacken part C so that no load is applied to the soldered wires. 2. Apply the clamp washer to the bifurcated part of the plug body, and then tighten the tightener until surface B touches the plug body surface A. Note : In order to prevent looseing, please apply an adhesive at the thread of plug body.	1. Fix by caulking the clamp accompanying the cable with the cable crimping tool(HR10A-TC-02) 2. Screw the plug body into the thread in the P shell until with a tightening force shown in Table 1 using a torque wrench with a fixed torque. Before tightening the plug body, slacken the part D so that no load is applied to the soldered wires. 3. Tighten the set screw so that the tip of the screw presses one of the two bosses on the clamp. Fix the set screw with a tightening torque of 0.3N (3kg·cm). 4. Attach the cord bushing to the plug body. Note : In order to prevent looseing, please apply an adhesive at the thread of plug body.
	5	This completes the work.

For any question on using the plugs, contact our sales or engineering department.

◆ Recommended Mounting Hole

Mounting hole dimension shown here is tight by hexagon nut from back side.

Shell size	7 size	10 size	13 size
Map mark			
A	1.6 ^{+0.1} ₀	2.6 ^{+0.1} ₀	
B	5.1 ^{+0.1} ₀	6.6 ^{+0.1} ₀	8.6 ^{+0.1} ₀
C	8.1 ^{+0.1} ₀	11.1 ^{+0.1} ₀	14.1 ^{+0.1} ₀
Panel thickness	0.7 to 2		0.8 to 1.5

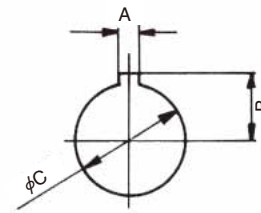

◆ Contact Arrangement

Shell size	7 size			10 size	
Contact arrangement					
No. of contacts	4	5	6	10	12
Withstanding voltage	AC500V for a minute	AC300V for a minute			
Current rating	2A				
Insulation resistance	MIN 1,000MΩ				
Contact resistance	MAX 10mΩ				
Solder pot inside dia.	φ0.8				

Shell size	10 size	13 size
Contact arrangement		
No. of contacts	10+coaxial contact	20
Withstanding voltage	AC300V for a minute	
Current rating	2A	
Insulation resistance	MIN 1,000MΩ	
Contact resistance	MAX 30mΩ	MAX 10mΩ
Solder pot inside dia.	—	φ0.8

Notes 1. The contact arrangement shown here is the mating surface of socket insert assembled.

2. The withstanding voltage shown here is test voltage value.
3. The insulation resistance value is measured at DC100V.
4. The contact resistance value is measured at DC1A.

◆ Precautions

1. Switch off the power of the circuit before disconnecting or plugging-in the connector.
2. Use a connector with socket contacts at the power side of the circuit.
3. Make sure that the coupling is in completely locked position.
4. Cable clamping, cable rotation, and other forces may vary with the cable construction. Please make sure that your cable is suitable for use with these connectors before usage and production.



HIROSE ELECTRIC CO.,LTD.

2-6-3,Nakagawa Chuoh,Tsuzuki-Ku,Yokohama-Shi 224-8540,JAPAN
 TEL: +81-45-620-3526 Fax: +81-45-591-3726
<http://www.hirose.com>
<http://www.hirose-connectors.com>