

# EM806 2-phase Digital Stepper Drive

## 24-80V, 0.35-6A, Sensorless Stall Detection, Pre-Matching Motor

- n **Sensorless stall detection** eliminates cost of feedback devices and time of cable connection
- n **Super-low** motor noise offers excellent quietness
- n **User password protection** prevents others from copying your drive configurations
- n **Anti-Resonance** optimizes torque and nulls mid-range instability
- n Self-test and Auto-configuration technology offers optimum performance for different motors
- n Multi-stepping allows a low resolution input to produce a higher microstep output for smoother system performance
- n Options to set output current and microstep resolutions via DIP switch or software
- n Command input of PUL/DIR, Microstep from 1 to 512
- n Automatic idle-current reduction and reduction rate is software configurable
- n Over-current, over-voltage, short-circuit protections besides sensorless stall detection
- n Fault out prevents damages to your machines or the materials



### Descriptions

By implementing the latest motion control technologies, Leadshine's EM series DSP-based stepper drives deliver excellent performance not available before. Unique features of sensorless stall detection, extra smoothness and excellent high speed performance make EM stepper drives deliver servo-like performance at the cost of stepper drives. They are capable of delivering high performance without damages to your machines or the materials. Leadshine EM series stepper drives are able to drive 2-phase or 3-phase stepper motors from NEMA8 to NEMA42.

### Applications

EM806 stepper drives are suitable for driving a wide range of 2-phase stepper motors, from NEMA frame size 23 to 42. Typical applications include CNC routers, laser cutters, laser markers, medical equipments, X-Y tables, measurement equipments, etc.

## Specifications

### Electrical Specifications

Parameter	Min	Typical	Max	Unit
Input Voltage	24	68	80	VDC
Pulse Input Frequency	0	-	200	kHz
Logic Signal Current	7	10	16	mA
Isolation Resistance	500	-	-	MΩ

### Operating Environment

Cooling	Natural Cooling or Forced cooling	
Operating Environment	Environment	Avoid dust, oil fog and corrosive gases
	Storage Temperature	-20°C – 65°C (-4°F – 149°F)
	Ambient Temperature	0°C – 50°C (32°F – 122°F)
	Humidity	40%RH – 90%RH
	Operating Temperature (Heat Sink)	70°C (158°F) Max
	Vibration	10-55Hz, 0.15mm/s
Storage Temperature	-20°C – 65°C (-4°F – 149°F)	
Weight	560g (19.75oz)	

## Mechanical Specifications

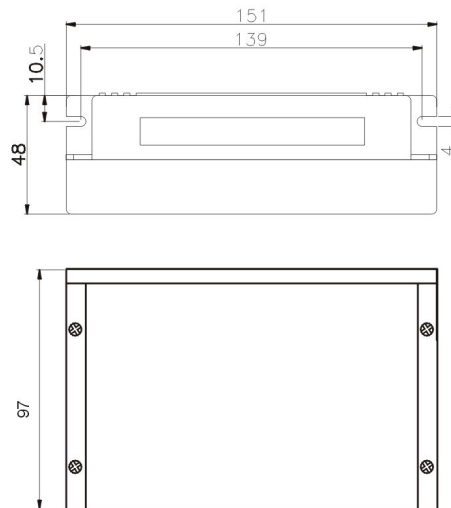

## Protection Indications

The green indicator turns on when power-up. When drive protection is activated, the red LED blinks periodically to indicate the error type

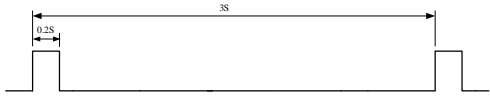
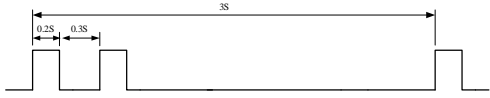
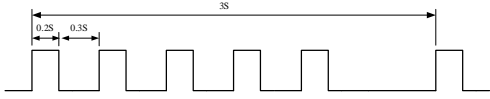
Priority	Time(s) of Blink	Sequence wave of RED LED	Description
1st	1		Over-current protection
2nd	2		Over-voltage protection
3rd	5		Motor Stall Protection

## Connectors and Pin Assignment

The EM806 has two connectors, connector for control signals connections, and connector for power and motor connections.

Control Signal Connector			
Pin	Name	I/O	Description
1	PUL+	I	<u>Pulse Signal</u> : This input represents pulse signal, each rising or falling edge active. 4-5V when PUL-HIGH, 0-0.5V when PUL-LOW. For reliable response, pulse width should be longer than 2.5 $\mu$ s. Series connect resistors for current-limiting when +12V or +24V used. The same as DIR and ENA signal.
2	PUL-	I	
3	DIR+	I	<u>Direction Signal</u> : This signal has low/high voltage levels, representing two directions of motor rotation. For reliable motion response, DIR signal should be ahead of PUL signal by 5 $\mu$ s at least. 4-5V when DIR-HIGH, 0-0.5V when DIR-LOW. Please note that rotation direction is also related to motor-driver wiring match. Exchanging the connection of two wires for a coil to the driver will reverse motion direction. The direction signal's polarity is software configurable.
4	DIR-	I	
5	ENA+	I	<u>Enable Signal</u> : This signal is used for enabling/disabling the driver. In default, high level (NPN control signal) for enabling the driver and low level for disabling the driver. Usually left <b>UNCONNECTED (ENABLED)</b> . Please note that PNP and Differential control signals are on the contrary, namely Low level for enabling. The active level of ENA signal is software configurable.
6	ENA-	I	
7	FLT+	O	<u>Fault Signal</u> : OC output signal, active when one of the following protection is activated: over-voltage, over current, short circuit and stall-error. This port can sink or source 20mA current at 24V. In default, the resistance between FLT+ and FLT- is low impedance in normal operation and become high when EM806 goes into error. The active level of fault signal is software configurable. See EM drives software operational manual for more detail.
8	FLT-	O	

Power and Motor Connector			
Pin	Name	I/O	Description
1	A+	O	Motor Phase A+
2	A-	O	Motor Phase A-
3	B+	O	Motor Phase B+
4	B-	O	Motor Phase B-
5	+Vdc	I	Power Supply Input (Positive), 24-72VDC recommended, leaving rooms for voltage fluctuation and back-EMF.
6	GND	GND	Power Ground (Negative)

### RS232 Communication Port

It is used to configure the peak current, microstep, active level, current loop parameters and anti-resonance parameters. See EM driver's software operational manual for more information.

RS232 Communication Port			
Pin	Name	I/O	Description
1	NC	-	Not connected.
2	+5V	O	+5V power only for STU (Simple Tuning Unit).
3	TxD	O	RS232 transmit.
4	GND	GND	Ground.
5	RxD	I	RS232 receive.
6	NC	-	Not connected.

### DIP Switch Settings

#### Dynamic Current

Peak	RMS	SW1	SW2	SW3
Default	Default	on	on	on
2.7A	1.93A	of	on	on
3.6A	2.57A	on	off	on
4.6A	3.29A	off	off	on
5.5A	3.93A	on	on	off
6.4A	4.57A	of	on	off
7.3A	5.21A	on	off	off
8.2A	5.86A	off	off	off

**Note:** Due to motor inductance, the actual current in the coil may be smaller than the dynamic current setting, particularly under high speed condition.

### Idle-Current

SW3 determines whether the idle current is reduced automatic or remains the same as the dynamic current setting.

	ON	OFF
SW4	The motor idle current reduces automatically when there is no pulse applied to EM806.	The motor idle current is the same as the dynamic current when there is no pulse applied to EM806.

### Auto-Configuration

Switch SW4 two times in two seconds to auto-configure the drive's current loop parameter. That is, OFF-ON-OFF or ON-OFF-ON. During Auto-configuration, motor parameters are identified and the EM drive's current loop parameters are calculated automatically. The motor shaft will vibrate a little during the process of Auto-configuration which takes about 1 to 3 seconds.

### Motor Selection and Pre-matching Leadshine Motor

There is a rotation switch used for the motor selection.

Matching Motor	Connection	Code	Description	
57HS09	Parallel	0	Select pre-matching Leadshine stepper motor. EM806 has been tuned for these motors.	
57HS13	Parallel	1		
57HS22	Parallel	2		
86HS35	Parallel	3		
86HS45	Parallel -	4		
86HS85	Parallel	5		
57HS09	Series	6		
57HS13	Series	7		
57HS22	Series	8		
86HS35	Series	9		
86HS45	Series	A		
86HS85	Series	B		
Custom1	-	C		Select non-Leadshine motor. EM806 needs tuning either by Auto-configuration or the PC software. There are up to four custom positions for customer selection.
Custom2	-	D		
Custom3	-	E		
Custom4	-	F		

### Pulse Active Edge

	ON	OFF
SW8	Active rising edge of pulse.	Active falling edge of pulse

**Microstep Resolution**

Steps/Revolution	SW5	SW6	SW7
Software Configured (Default 200)	on	on	on
400	off	on	on
800	on	off	on
1600	off	off	on
3200	on	on	off
6400	off	on	off
12800	on	off	off
25600	off	off	off

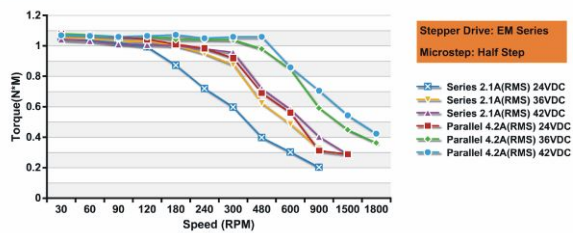
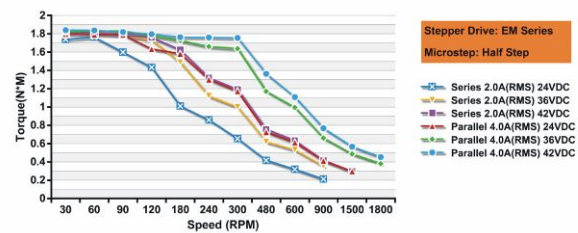
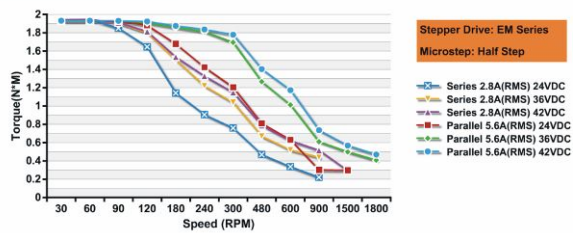
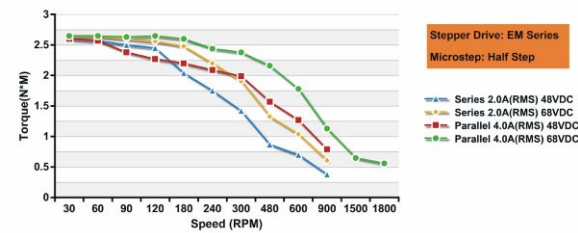
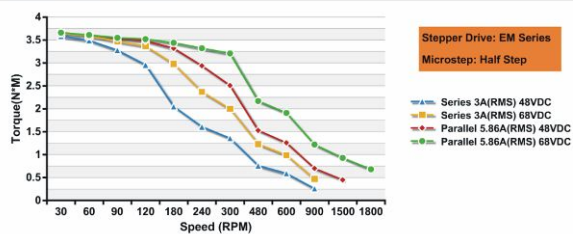
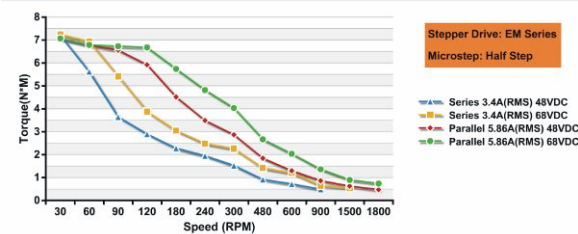
**Speed Torque Curve for Pre-matching Leadshine Motor**
**Stepper Motor: 57HS09**

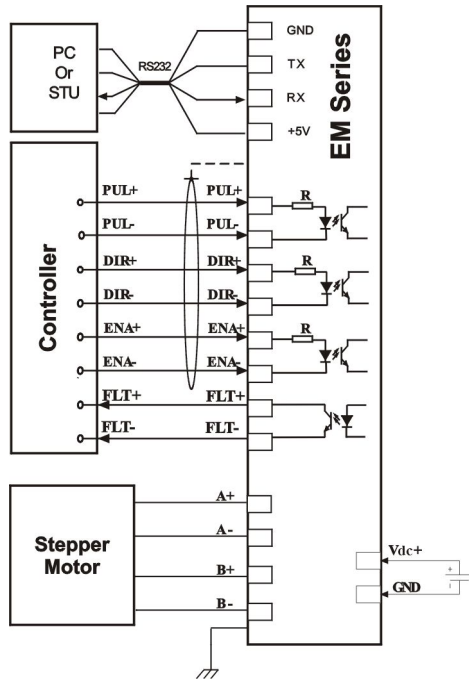
**Stepper Motor: 57HS13**

**Stepper Motor: 57HS22**

**Stepper Motor: 86HS35**

**Stepper Motor: 86HS45**

**Stepper Motor: 86HS85**

**Typical Connections**
**Differential Control Signal**

**NPN Control Signal**
