

SYNCHRONOUS MOTORS

Superior
Electric

www.DanaherMotion.com



 Solutions by
DANAHER
MOTION

Danaher Motion and Superior Electric

Superior Electric is a Danaher Motion brand, and is recognized worldwide as the leading manufacturer of synchronous motors. Over 40 years ago, Superior Electric developed and patented their synchronous motors.

The Superior Electric family of automation products includes:

- Step Motors
- Step Motor Drives
- Motion Controls
- Synchronous Motors

This catalog highlights the latest selection of high torque synchronous motors from Superior Electric. Our new line of NEMA size 42 high torque motors complements and extends the range of our size 23 and 34 high torque motors. These motors provide world-class performance, and represent the best value of any lineup ever offered by Superior Electric. They provide twice the torque (and in some cases more than twice the torque) of older conventional synchronous motors.

Your partner in Motion Control

Danaher Motion offers a comprehensive line of motors, drives, controls, and actuators designed to optimize the performance of motion control systems. These address a wide array of requirements, ranging from simple repetitive moves to complex multi-axis motion. On-going product development enables Danaher Motion to provide innovative, leading edge solutions to our customers.

One of the best reasons to select a Superior Electric product is Danaher Motion's superior service and support. Our products are available globally through the industry's most extensive and experienced distributor network. These trained distributors provide valuable technical assistance, in addition to fast delivery and service. A team of application engineers backs our distributor network. The combined experience of this support system ensures that our customers receive prompt, quality attention to their needs, no matter where they are located.

Danaher Motion has extensive experience customizing motors to meet specific design requirements. Our engineering staff will work with you to achieve your product performance goals.

Further assistance and support is provided on the web at www.DanaherMotion.com. Visitors to this site will find product information, technical specifications, and information on our distribution network.

Table of Contents

Introduction to Synchronous Motors	3
Synchronous Motor Characteristics	4-5
KS06, KS09, KS11 Series – High Torque – NEMA 23, 34, 42	6-9
SS240, SS450 Series – NEMA Size 34	10-13
Hazardous Duty Motors – NEMA Sizes 42, 66	14-16
Phase Shifting Components	17
Gearbox Kits & Gearmotors	18-20
Application Assistance	21-22
Conversion Factors	23

Introduction to Synchronous Motors

These motors offer substantial advantages in applications needing their very unique capabilities.



Superior Electric synchronous motors are high pole count motors that naturally turn at slower speeds (72 or 60 rpm). They only need a resistor – capacitor (RC) network to operate from single-phase AC utility power. For loads that operate at 72 RPM or slower, they are very cost effective and simple to use.

Other motor technologies (induction, DC, servo and step motors) either need gear reducers, or electronic drives to match the speed of Superior Electric synchronous motors. The cost of just the gear reduction or the cost of the electronic drive will usually exceed the total cost of the Superior Electric synchronous motor.

For even slower speeds planetary gear reducers are offered. Superior Electric synchronous motors produce very low speeds with only modest gear reductions.

Performance Features

- 72 rpm motor speed (with 60 Hz voltage)
- 60 rpm motor speed (with 50 Hz voltage)
- Constant speed does not vary with the load
- 120 volt or 240 volt AC models
- Torques: 70 to 1,500 oz-in (50-1,069 N-cm)
- Gear reducers with ratios up to 125:1 and torques up to 5,000 oz-in (3,670 N-cm)
- UL and CE hazardous duty versions
- Fast starting, stopping, or reversing
- Can be stalled indefinitely without overheating

High Torque Motor Construction

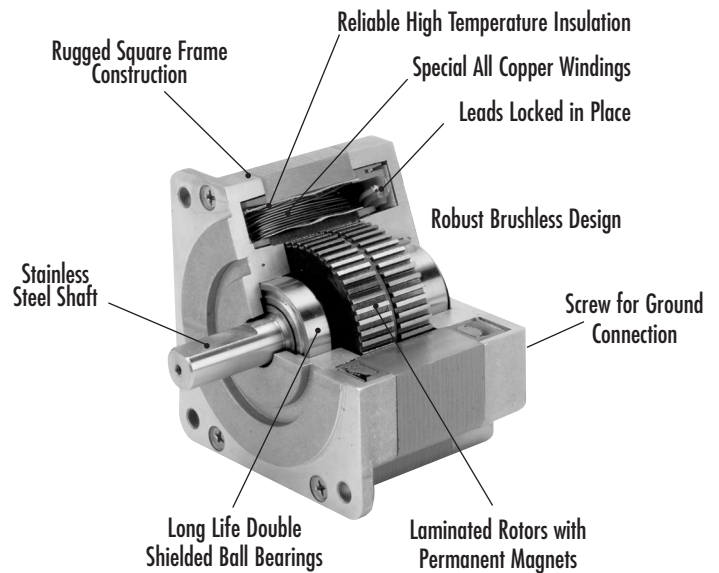

Typical Applications

Due to their ease of use and inherent slow speeds, Superior Electric synchronous motors are used in a wide variety of applications including:

- Stirring
- Valve operation
- Metering pumps
- Cryogenic pumps
- Simple position & process controls
- Linear actuators
- Edge guides
- Variable transformers
- Dampers
- Conveyor systems
- Table lifts
- Remote control of switches, antennas, etc.

Synchronous Motor Characteristics

Starting and Stopping

Rapid starting, stopping and reversing are among the advantages of Superior Electric synchronous motors. The motors will start within 1-1/2 cycles of the applied frequency and will stop within 5°. As shown in the typical starting curve, these motors will start and reach its full synchronous speed within 5 to 25 milliseconds.

Typical Starting Characteristics for a 72 rpm Motor

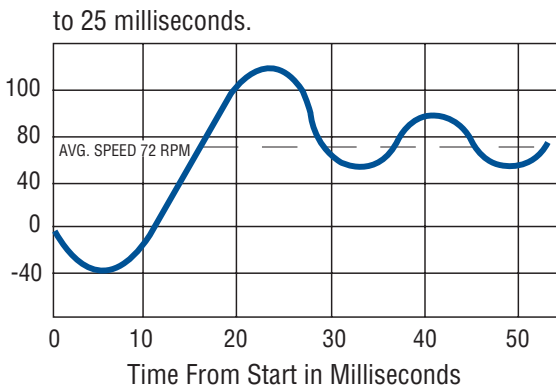

Phase-Shifting Network

The KS series and hazardous duty motors use a two-phase winding design. They are usually operated from single-phase AC power using a phase shifting network consisting of one or two resistors and a capacitor. These motors can also be operated directly from a two-phase power source.

The SS240 – SS450 series use a three phase winding design. They can be driven directly from three-phase voltage or can be operated from single-phase power using only a phase shifting capacitor.

Ratings and part numbers for the phase-shifting components are shown in the motor charts. Detailed phase shifting component information is given on page 17. Be sure to select the correct components for the frequency of the AC power source, since the components needed for 50 hertz operation may be different from those required for operation at 60 hertz.

Temperature

All Superior AC synchronous motors are rated for continuous duty at a maximum ambient temperature of 40°C (104°F). Motor shell temperature must not be allowed to exceed 100°C (212°F) measured with a thermocouple. The minimum ambient temperature at which the motors may be operated is -40°C (-40°F).

Starting and Running Current

It is not necessary to consider high starting currents when designing a control system for a Superior Synchronous motor, since starting and operating current are, for all practical purposes, identical.

Stalling

If a motor becomes stalled, it will not overheat and will continue to draw only rated current. However, if the motor is stalled by running up against a stop, it will vibrate against the stop. Operating the motor continuously in this manner may eventually cause bearing failure.

Torque Versus Voltage

As indicated in the curve, the torque output of a Superior motor is approximately proportional to the applied input voltage. For intermittent operation, this characteristic can be used to provide increased torque by increasing the voltage. For example, assume that an application has a torque requirement of 200 ounce-inches (141 N-cm). Normally, a 240 ounce-inch (169 N-cm) Superior motor would be adequate, but this application is subject to wide voltage fluctuations and, therefore, the 40 ounce-inch (28 N-cm) safety margin may be insufficient. The recommended practice is to use a motor having a higher torque rating. However, a larger motor may not fit in the available space. In this case, a step-up transformer could be used to increase the voltage to the 240 ounce-inch motor by approximately 10%. Because operation at a higher voltage will cause a greater temperature rise, care must be taken to assure motor shell temperature does not exceed 100°C (212°F).

Typical Torque Versus Voltage for a Superior Motor

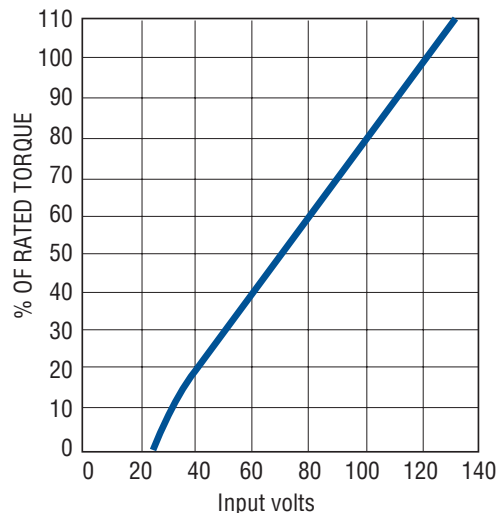

Synchronous Motor Characteristics (Continued)

Speed Versus Frequency

Frequency (Hertz)	Speed
	72 rpm at 60 Hertz Models
10	12
20	24
30	36
40	48
50	60
60	72
70	84
80	96

The speed of a synchronous motor is directly proportional to the applied frequency, as shown in the Speed vs. Frequency chart. However, because the winding impedance is also a function of frequency it is necessary to adjust the voltage, to provide a constant current and torque at different excitation frequencies.

The voltage required at a specific frequency can be obtained from the Voltage vs. Frequency curve. When a two-phase motor is operated from a two-phase source or a three-phase motor is operated from a three-phase source, it is only necessary to change the voltage and frequency to obtain the desired synchronous speed. When operating from a single-phase source it is necessary to change the values of the phase shifting components at each new frequency to provide the required phase shift.

Typical Voltage Versus Frequency for a Superior Motor

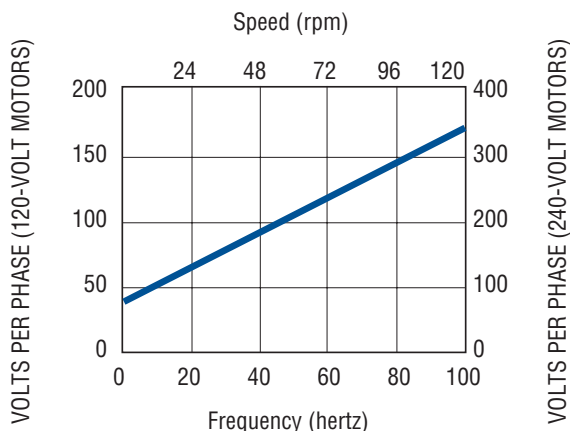

Holding Torque

The permanent magnet construction of a Superior motor provides a small residual torque which helps hold the motor shaft in position when the motor is de-energized. When additional holding torque is required, DC current can be applied to one winding when the ac input is removed. DC current can also be applied to both windings if more holding torque is needed. The diagrams show typical connections for applying DC current to increase holding torque. Contact factory for voltage, current and holding torque specifications.

Typical Connections for Applying DC Current to Increase Holding Torque

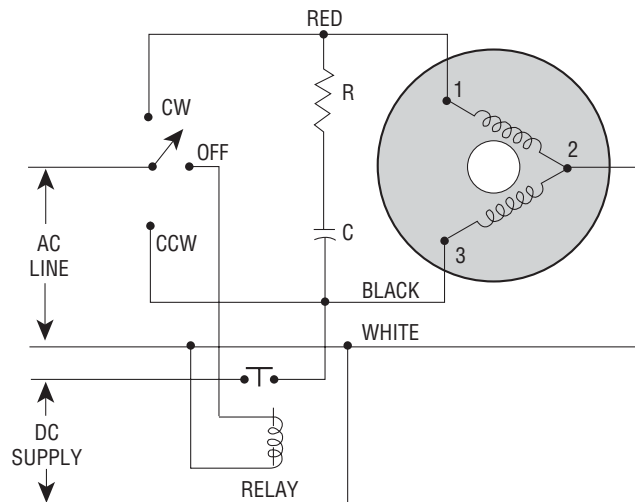

KS06, KS09, KS11 Series

High Torque 60mm, 90mm, and 110mm Frame Sizes (NEMA Sizes 23, 34, 42)

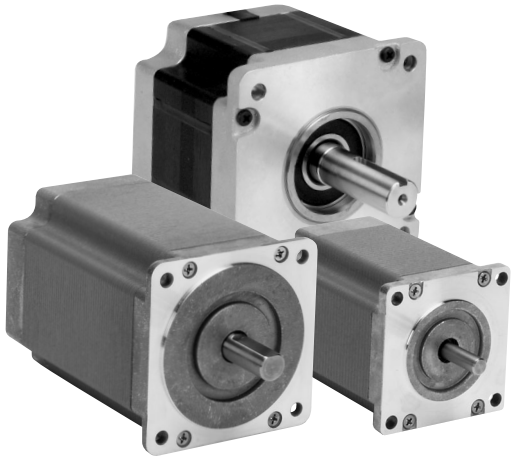

- Latest high torque construction
 - Motor torque up to 1500 oz-in (1059 N-cm)
 - 72 RPM @ 60 Hz - 60 RPM @ 50 Hz
 - 120 and 240 volt AC versions
 - Patented RRC network for smoother operation
 - Leaded or terminal box connections
 - Gearboxes available on KS09, NEMA 34 motors
- See pages 18 & 19 for ratings

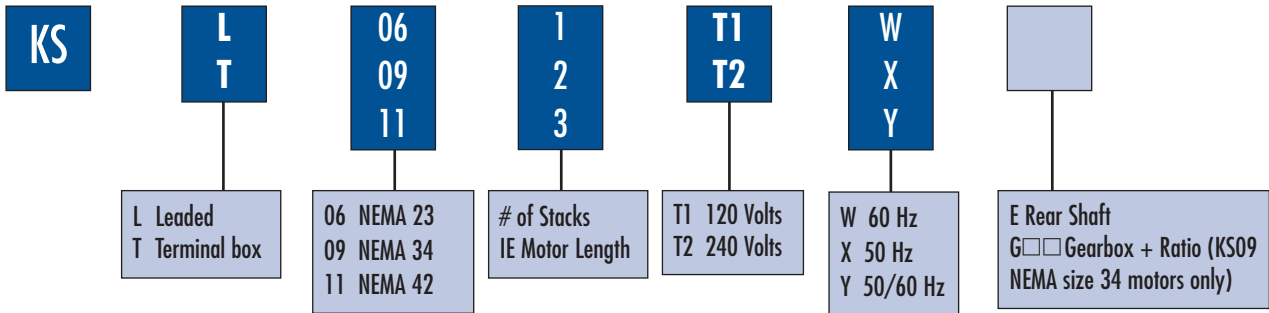

120 Volt, 60 Hz, Single Phase, 72 RPM

* Type Number	Torque (min)		# Load Inertia		amps	Wiring Diagram	Phase Shifting Components					
	oz-in	N-cm	lb-in ²	kg-cm ²			Resistor(s)			Capacitor (240 VAC)		
							Kit Number	ohms	watt	Kit Number	μF	
KS06	^KS□061T1Y	70	49	0.7	2.0	0.25	R/R/C	201052-034	600	12	201053-068	1.5
	KS□061T1Y	80	56	0.5	1.5	0.25	R/C	201052-033	1,000	12	201053-038	2
	KS□062T1Y	140	99	2.0	5.9	0.35	R/C	201052-035	600	25	201053-044	3
	KS□063T1Y	185	131	4.0	12	0.40	R/C	201052-049	400	50	201053-076	5
KS09	KS□091T1Y	240	169	4	12	0.50	R/C	201052-037	300	50	201053-076	5
	KS□092T1Y	450	318	8	23	0.60	R/C	201052-041	250	50	201053-069	6
	KS□093T1Y	700	494	13	38	1.00	R/C	201052-027	150	100	201053-074	11
KS11	KS□111T1W	700	494	7	20	1.20	R/C	201052-045	100	100	201053-032	12.5
	KS□112T1W	1,100	777	13	38	1.70	R/C	201052-101	75	100	201053-081	20
	KS□113T1W	1,500	1,059	15	44	2.10	R/C	201052-104	50	200	201053-081	20

^ Use this RRC phase shifting arrangement if very smooth operation is desired.

KS06, KS09, KS11 Series (Continued)

240 Volt, 60 Hz, Single Phase, 72 RPM

	* Type Number	Torque (min)		# Load Inertia		amps	Wiring Diagram	Phase Shifting Components				
		oz-in	N-cm	lb-in ²	kg-cm ²			Resistor(s)			Capacitor (370 VAC)	
								Kit Number	ohms	watt	Kit Number	μF
KS06	KS□062T2Y	140	99	2.3	6.7	0.15	R/R/C	201052-036	1,100	25	201053-063	0.75
	KS□063T2Y	185	131	2.6	7.6	0.20	R/R/C	201052-050	1,000	25	201053-063	0.75
KS09	KS□091T2Y	240	169	4	12	0.25	R/R/C	201052-039	900	50	201053-070	1
	KS□092T2Y	450	318	9	26	0.35	R/C	201052-045	1,000	100	201053-072	2
	KS□093T2Y	700	494	14	41	0.50	R/C	201052-047	600	100	201053-073	3
KS11	KS□111T2W	700	494	9	26	0.60	R/C	201052-028	500	100	201053-030	3
	KS□112T2W	1,100	777	18	53	0.90	R/C	201052-102	200	100	201053-030	3
	KS□113T2W	1,500	1,059	17	50	1.30	R/C	201052-105	200	200	201053-029	6

240 Volt, 50 Hz, Single Phase, 60 RPM

	* Type Number	Torque (min)		# Load Inertia		amps	Wiring Diagram	Phase Shifting Components				
		oz-in	N-cm	lb-in ²	kg-cm ²			Resistor(s)			Capacitor (370 VAC)	
								Kit Number	ohm	watt	Kit Number	μF
KS06	KS□062T2Y	140	99	2.3	6.7	0.15	R/R/C	201052-036	1,100	25	201053-063	0.75
	KS□063T2Y	185	131	2.6	7.6	0.20	R/R/C	201052-050	1,000	25	201053-070	1
KS09	KS□091T2Y	240	169	4.5	13	0.25	R/R/C	201052-039	900	50	201053-075	1.5
	KS□092T2Y	450	318	8	23	0.35	R/R/C	201052-043	600	50	201053-071	1.75
	KS□093T2Y	700	494	14	41	0.50	R/R/C	201052-046	400	100	201053-073	3
KS11	KS□111T2X	700	494	5	15	0.60	R/C	201052-041	250	50	201053-030	3
	KS□112T2X	1,100	777	18	53	0.70	R/C	201052-103	250	100	201053-028	4
	KS□113T2X	1,500	1,059	27	79.0	1.40	R/C	201052-106	150	200	201053-082	7.5

This is the maximum rigidly attached load inertia the motor will reliably start. If the load is attached to the motor with a coupling that has a 5° flex, the motors can start loads up to seven times listed.

Connection Diagrams

R/C Connection

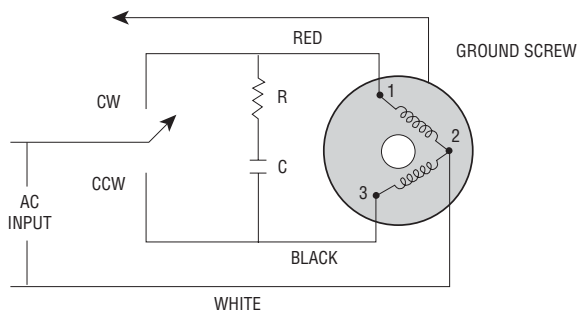

R/R/C Connection

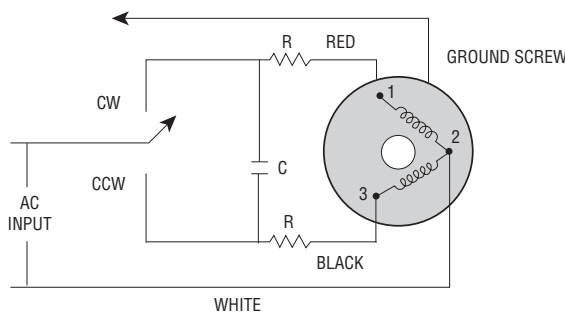

NOTE:

1 - Direction or rotation is determined when viewed from end opposite mounting surface.

2 - Number in diagrams represent terminal connection when motors are supplied with terminal boards.

Single-Phase Operation

Two-Phase Operation

KSL06 Leaded

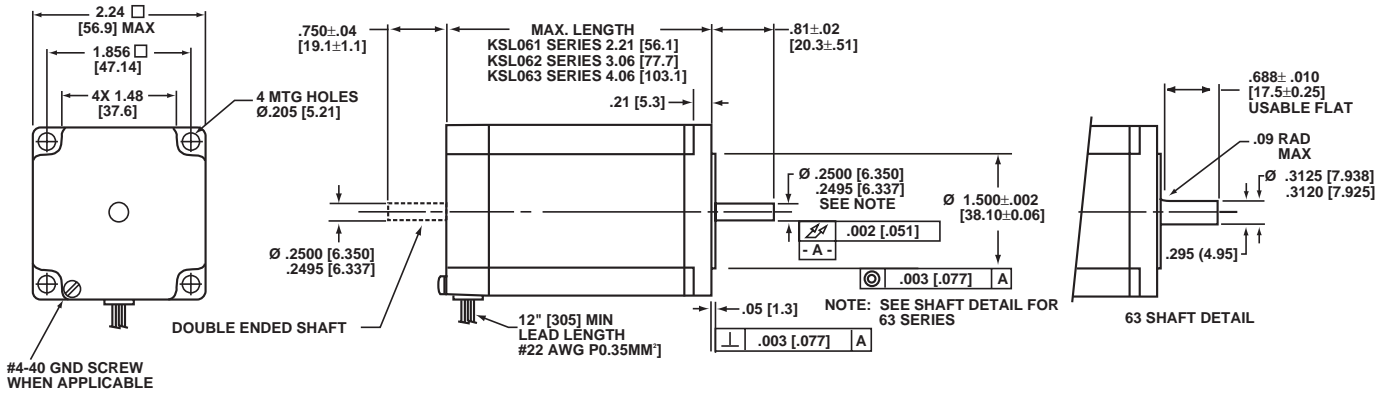

KST06 Terminal Box

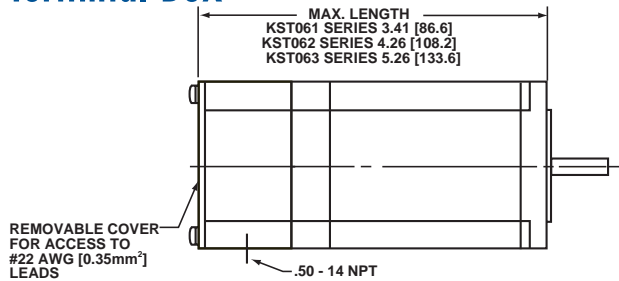

Dimensions are shown in inches (mm)

KSL11 Leaded

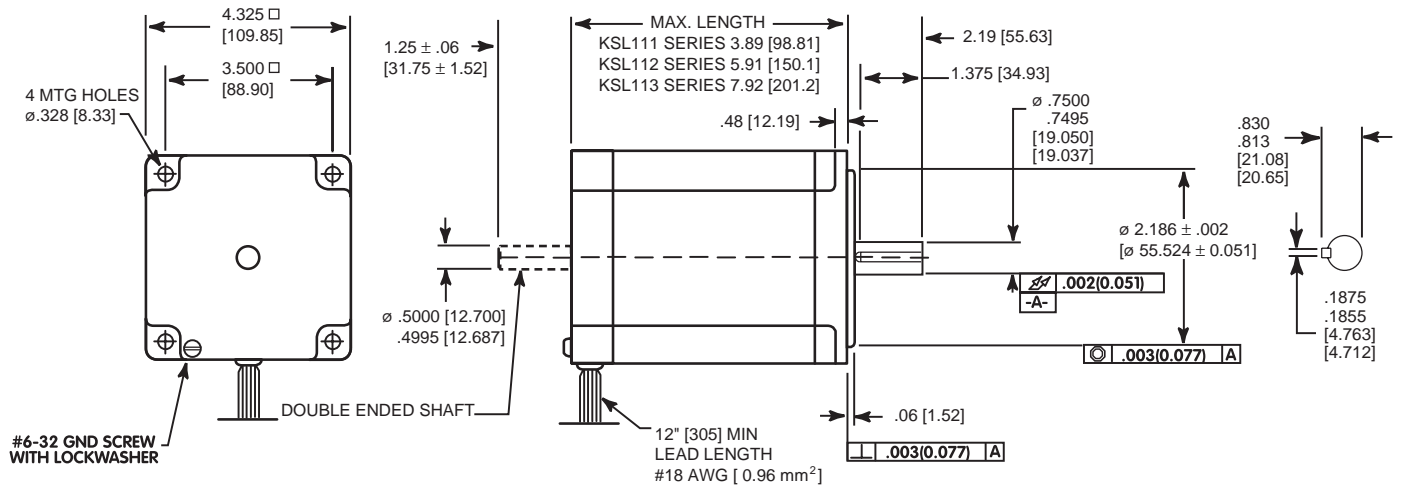

KST11 Terminal Box

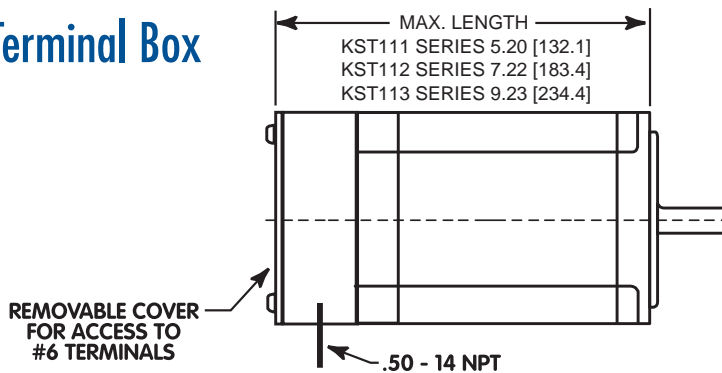

Dimensions are shown in inches (mm)

KSL09 Leaded

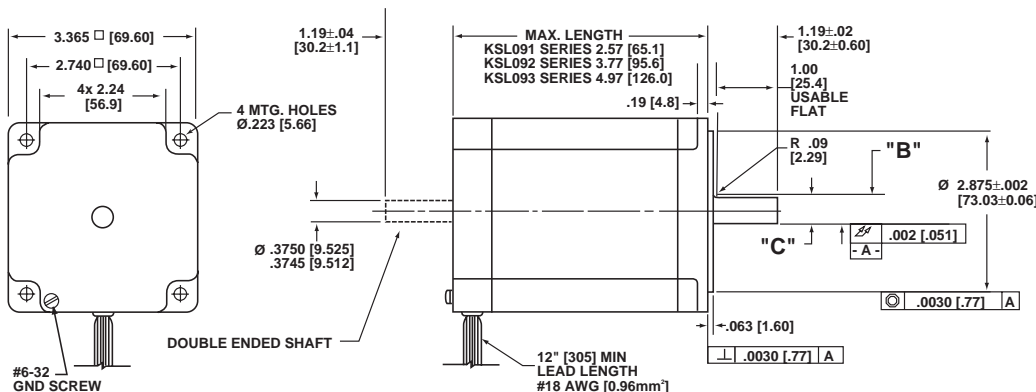

Shaft Dimensions				
Motor Series	"B" Dia.		"C" Flat	
	in	mm	in	mm
KS□091	0.3750	9.525	0.328	8.33
	0.3745	9.512		
KS□093	0.5000	12.700	0.450	11.43
	0.4995	12.687		

KST09 Terminal Box

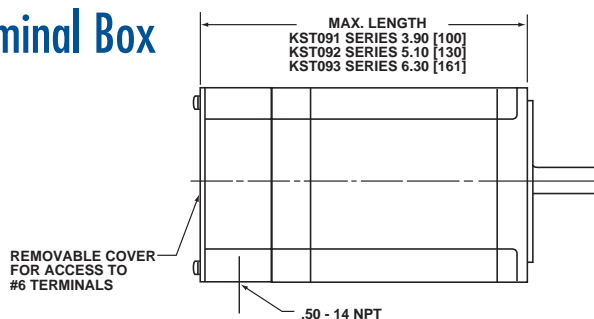

KS09 Gearmotors

See pages 18 & 19 or gearbox information

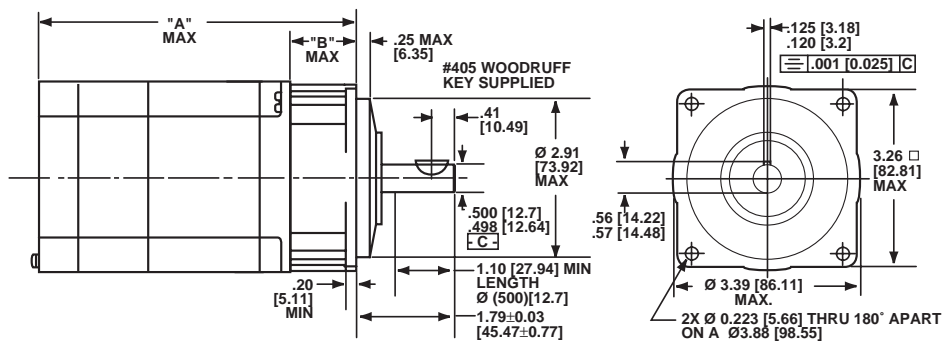

Motor Series	Gearbox Ratio	inch B mm	Leaded Motors		Terminal Box Motors	
			Leaded Series	inch A mm	Terminal Motors	inch A mm
KS□091	3:1 thru 5:1	1.19 30.2	KSL091	3.76 96	KST091	5.09 129
	9:1 thru 25:1	1.81 46.0		4.38 111		5.71 145
	27:1 thru 125:1	2.38 60.5		4.95 126		6.28 160
KS□092	3:1 thru 5:1	1.19 30.2	KSL092	4.96 126	KST092	6.29 160
	9:1 thru 25:1	1.81 46.0		5.58 142		6.91 176
	27:1 thru 125:1	2.38 60.5		6.15 156		7.48 190
KS□093	3:1 thru 5:1	1.19 30.2	KSL093	6.16 156	KST093	7.49 190
	9:1 thru 25:1	1.81 46.0		6.78 172		8.11 206
	27:1 thru 125:1	2.38 60.5		7.35 187		8.68 220

Dimensions are shown in inches (mm)

SS240, SS450 Series

90mm Frame Size (NEMA Sizes 23, 34, 42)



- Motor torque up to 450 oz-in (1059 N-cm)
- 72 RPM @ 60 Hz - 60 RPM @ 50 Hz
- 120 and 240 volt AC versions
- Needs only a capacitor to operate from single-phase power
- Available with integral capacitor for single phase operation
- Operates directly from three-phase power
- Leaded, connector or terminal box connections
- Planetary gearboxes available – See pages 18 and 20

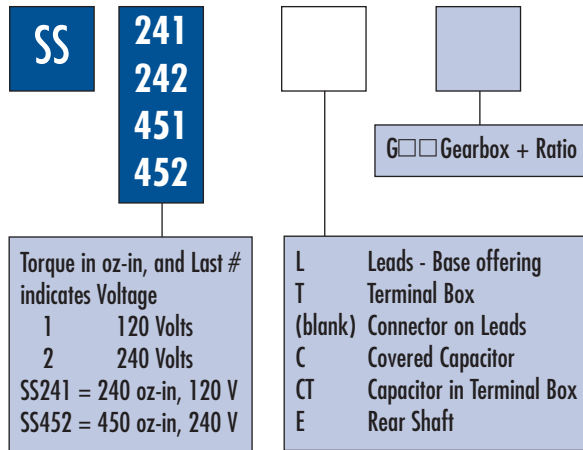

120 Volt, 60 Hz, Single Phase, 72 RPM

* Type Number	voltage	Torque (min)		# Load Inertia		amps	Wiring Diagram	Phase Shifting Capacitor (250 VAC)	
		oz-in	N-cm	lb-in ²	kg-cm ²			Kit Number	μF
SS241□	120	240	169	2.5	7	0.40	C	201053-037	7.5
SS451□	120	450	318	5.5	16	0.80	C	201053-042	14

240 Volt, 60 Hz, Single Phase, 72 RPM

* Type Number	voltage	Torque (min)		# Load Inertia		amps	Wiring Diagram	Phase Shifting Capacitor (250 VAC)	
		oz-in	N-cm	lb-in ²	kg-cm ²			Kit Number	μF
SS242□	208/240	240	169	2.5	7	0.20	C	201053-038	2
SS452□	208/240	450	318	7.5	22	0.30	C	201053-044	3

240 Volt, 50 Hz, Single Phase, 60 RPM

* Type Number	voltage	Torque (min)		# Load Inertia		amps	Wiring Diagram	Phase Shifting Capacitor (250 VAC)	
		oz-in	N-cm	lb-in ²	kg-cm ²			Kit Number	μF
SS242□	240	240	169	1	3	0.20	C	201053-038	2
SS242□	220	240	169	1	3	0.20	C	201053-041	2.5
SS452□	220/240	450	318	2	6	0.30	C	201053-061	4

SS240, SS450 (Continued)

Three Phase, 208 - 240 Volt, 60 Hz, 72 RPM

* Type Number	voltage	Torque (min)		# Load Inertia		amps	Wiring Diagram
		oz-in	N-cm	lb-in ²	kg-cm ²		
SS242□	208/240	250	177	2.5	7	0.20	3 Ø
SS452□	208	475	335	4.5	13	0.30	3 Ø

Three Phase, 208 Volt, 50 Hz, 60 RPM

* Type Number	voltage	Torque (min)		# Load Inertia		amps	Wiring Diagram
		oz-in	N-cm	lb-in ²	kg-cm ²		
SS242□	208	250	177	4	12	0.20	3 Ø
SS452□	208	475	335	4.5	13	0.30	3 Ø

Connection Diagrams

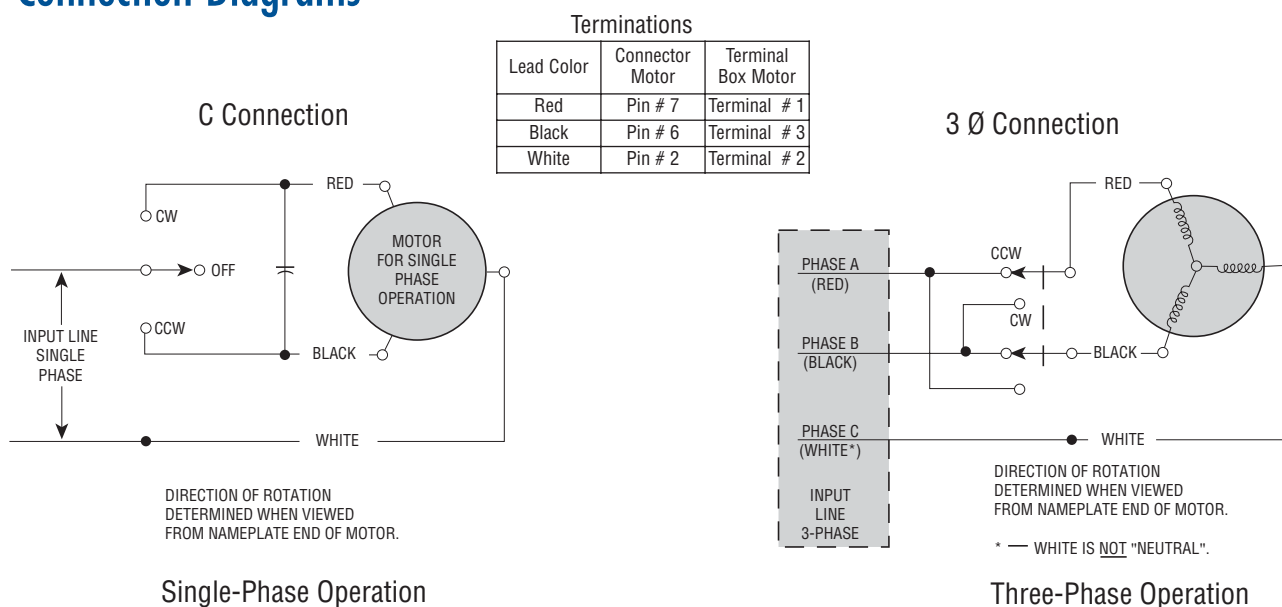

Mating Connector with Leads

Part number 225505-001

Mating connectors with 36" (914mm) long leads are available for making connections to motors that have connectors.

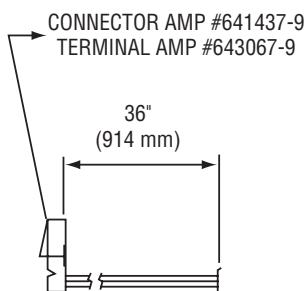

SS240, SS450 (Continued)

Leaded Motor

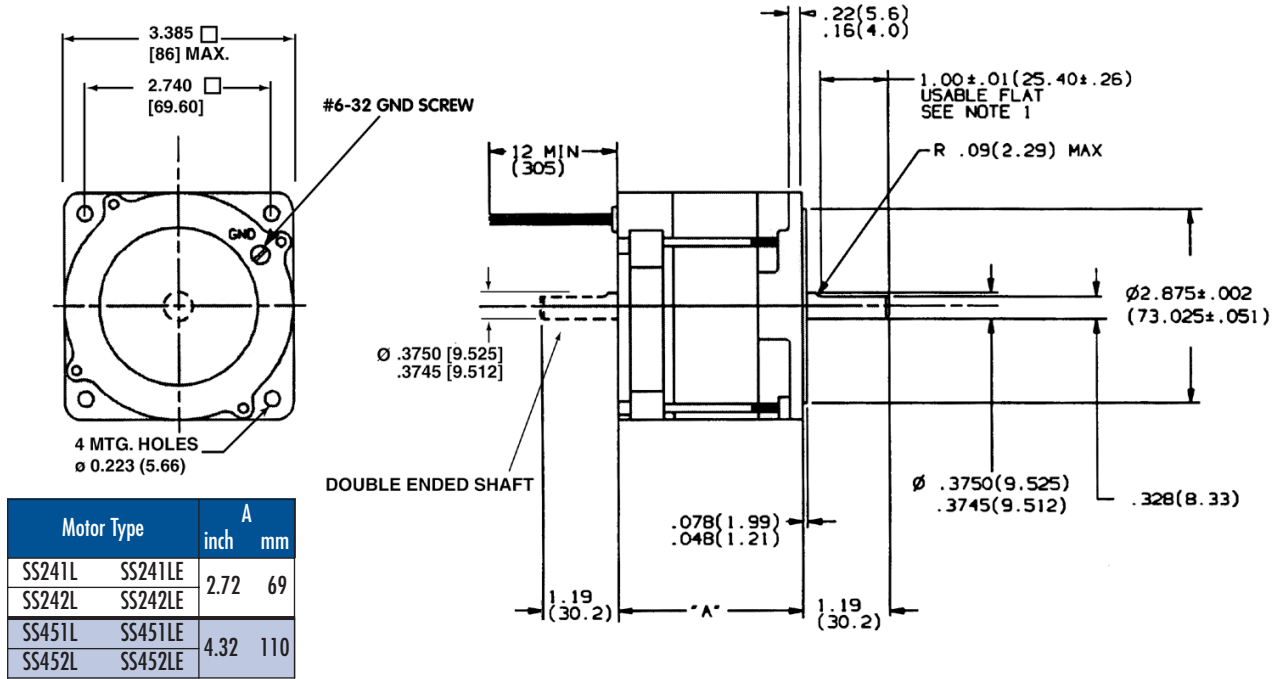

Terminal Box

Motor Type	A	inch	mm
SS241T	4.05	103	
SS242T	5.65	144	

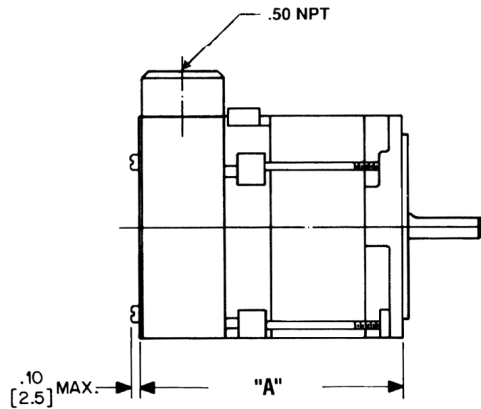

Connector

Motor Type	Connector	Terminal
SS241	SS241E	
SS242	SS242E	
SS451	SS451E	
SS452	SS452E	

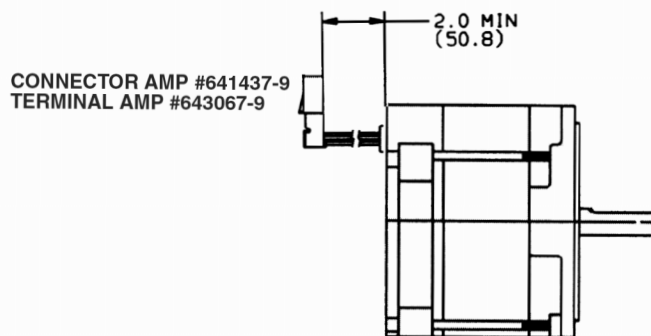

Dimensions are shown in inches (mm)

Covered Capacitor

Motor Type	A	
	inch	mm
SS241C	4.69	119
SS242C		
SS451C	6.29	160
SS452C		

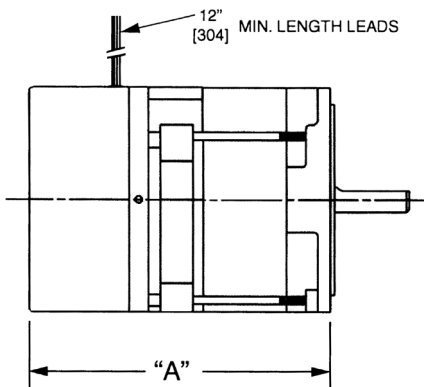

Capacitor in Terminal Box

Motor Type	A	
	inch	mm
SS241CT	5.48	139
SS242CT		
SS451CT	7.08	180
SS452CT		

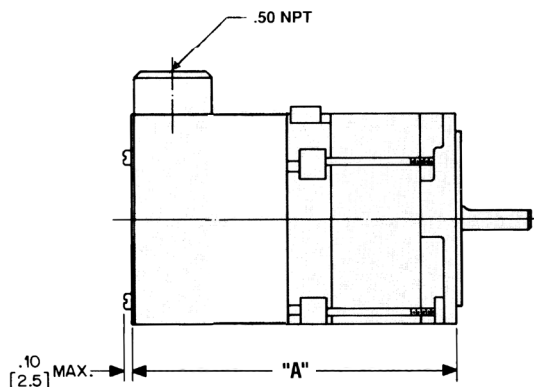

Gearmotors

See pages 18 and 20 for gearbox information

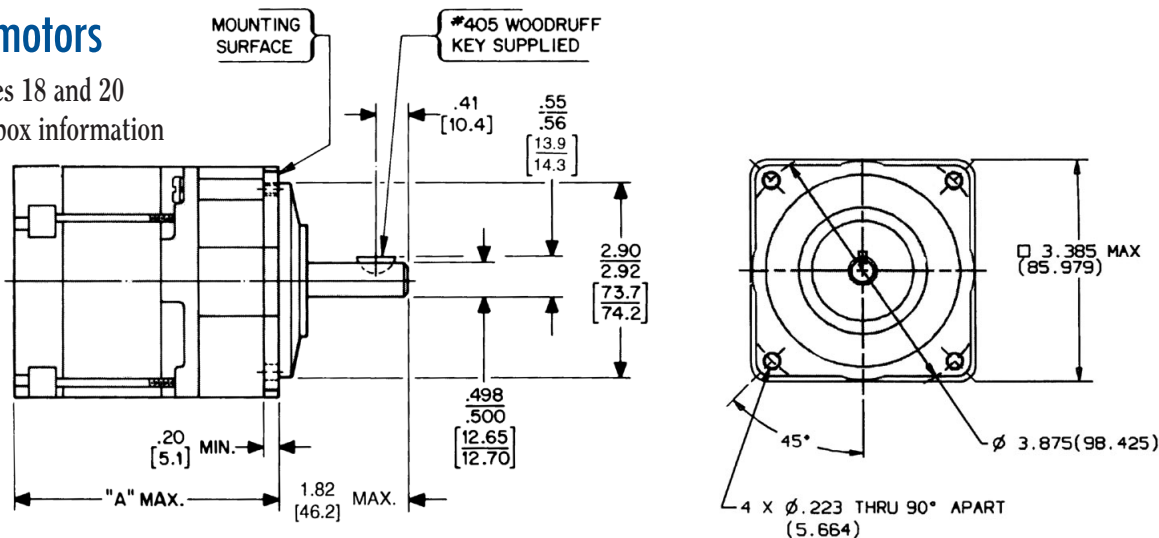

Motor Series	Gearbox Ratio	B		Leaded & Connector Motors				Terminal Box Motors				Covered Capacitor Motors				Capacitor in Terminal Box Motors			
				Leaded Motors		Connector Motors		Motor Type		Motor Type		Motor Type		Motor Type		Motor Type			
		inch	mm	inch	mm	inch	mm	inch	mm	inch	mm	inch	mm	inch	mm	inch	mm		
SS240	3:1 thru 5:1	1.19	30.2	S241LG□□	SS241G□□	3.91	99	SS241TG□□	5.24	133	SS241CG□□	5.88	149	SS241CTG□□	6.67	169			
	9:1 thru 25:1	1.81	46.0	SS242LG□□	SS242G□□	4.53	115	SS242TG□□	5.86	149	SS242CG□□	6.50	165	SS242CTG□□	7.29	185			
	27:1 thru 125:1	2.38	60.5			5.10	130		6.43	163		7.07	180		7.86	200			
SS450	3:1 thru 5:1	1.19	30.2	SS451LG□□	SS451G□□	5.51	140	SS451TG□□	6.84	174	SS451CG□□	7.48	190	SS451CTG□□	8.27	210			
	9:1 thru 25:1	1.81	46.0	SS452LG□□	SS452G□□	6.13	156	SS452TG□□	7.46	189	SS452CG□□	8.10	206	SS452CTG□□	8.89	226			
	27:1 thru 125:1	2.38	60.5			6.70	170		8.03	204		8.67	220		9.46	240			

Dimensions are shown in inches (mm)

Hazardous Duty Motors

(NEMA Size 42 & 66)

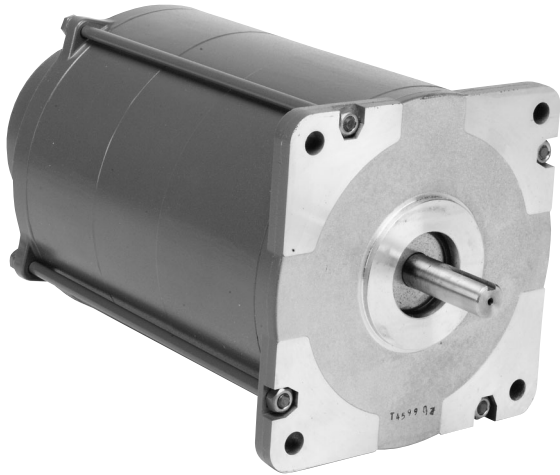

- Motor torque up to 1500 oz-in (1059 N-cm)
- 72 RPM @ 60 Hz - 60 RPM @ 50 Hz
- 120 and 240 volt AC versions
- UL Listed and CE certified versions
- UL Listed versions - Class 1 Group D requirements
- UL Listed versions have conduit connection
- CE certified versions – EEx d IIC T5
- CE certified versions have integral 10 ft (3 M) cable



X Meets UL Standards
(conduit connection)
XCE Meets CE Standards
(includes 10' (3m) cable)



Torque in oz-in, and
Last # indicates voltage
0 120 volts
2 240 volts
X250=250 oz-in, 120 V
X1102=1100 oz-in, 240 V



UL Certified Motors (Prefix "X")

Motors having an "X" prefix (X250, etc.) are designed to meet UL Standard 674 for motors operating in Class 1 Group D hazardous locations.

Class 1 is defined as locations in which gases or vapors are, or may be, present in the air in quantities sufficient to produce explosions or ignitable mixtures. Group D includes atmospheres containing gasoline, petroleum, naphtha, alcohol, acetone, lacquer solvent vapors or natural gas.



CE Certified Motors (Prefix "XCE")

Motors having a "XCE" prefix are designed to meet requirements in hazardous locations as defined by CE directive 94/9/EC. They have a flameproof enclosure, for use in surface industries exposed to gasses including hydrogen and acetylene. The maximum surface temperature is 100°C.

Hazardous Duty Motors (Continued)

120 Volt, 60 Hz, Single Phase, 72 RPM

* Type Number		Torque (min)		# Load Inertia		amps	Wiring Diagram	Phase Shifting				
UL	CE	oz-in	N-cm	lb-in ²	kg-cm			Resistor			Capacitor (330VAC)	
								Kit Number	ohms	watts	Kit Number	μF
X250	XCE250	250	177	3	8.8	0.6	RC	201052-013	150	50	201053-010	6.5
X700	XCE700	700	494	10	30	1.1	RC	201052-027	150	100	201053-032	12.5
X1100	XCE1100	1,100	777	9	26	3	RC	201052-025	100	160	201053-026	17.5
X1500	XCE1500	1,500	1,059	12	35	3	RC	201052-020	55	375	201053-014	30

240 Volt, 60 Hz, Single Phase, 72 RPM

* Type Number		Torque (min)		# Load Inertia		amps	Wiring Diagram	Phase Shifting				
UL	CE	oz-in	N-cm	lb-in ²	kg-cm			Resistor			Capacitor (660VAC)	
								Kit Number	ohms	watts	Kit Number	μF
X252	XCE252	250	177	3	8.8	0.4	RC	201052-015	500	50	201053-012	1.75
-----	XCE702	700	494	10	30	0.6	RC	201052-028	500	100	201053-030	3
X1102	XCE1102	1,100	777	9	26	1.5	RC	201052-026	400	160	201053-028	4
X1502	XCE1502	1,500	1,059	12	35	1.5	RC	201052-018	250	200	201053-016	8

240 Volt, 50 Hz, Single Phase, 60 RPM

* Type Number		Torque (min)		# Load Inertia		amps	Wiring Diagram	Phase Shifting				
UL	CE	oz-in	N-cm	lb-in ²	kg-cm			Resistor			Capacitor (660VAC)	
								Kit Number	ohms	watts	Kit Number	μF
X252	XCE252	250	177	3	8.8	0.4	RC	201052-015	500	50	201053-012	1.75
-----	XCE702	700	494	10	30	0.6	RC	201052-028	500	100	201053-028	4
X1102	XCE1102	1,100	777	9	26	1.5	RC	201052-026	400	160	201053-029	6
X1502	XCE1502	1,500	1,059	12	35	1.5	RC	201052-018	250	200	201053-019	9

This is the maximum rigidly attached load inertia the motor will reliably start. If the load is attached to the motor with a coupling that has a 5° flex, the motor can start loads up to seven times listed.

Connection Diagram

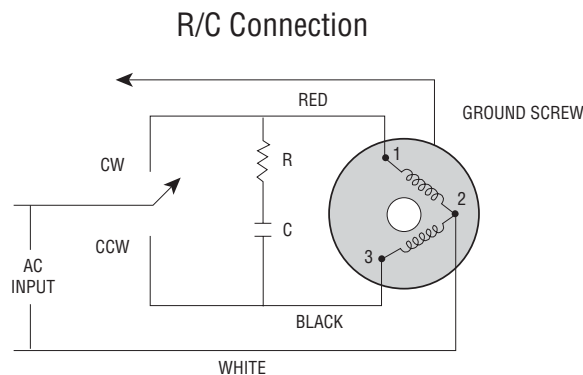

NOTE:
1 - Direction or rotation is determined when viewed from end opposite mounting surface.

Single-Phase Operation

Hazardous Duty Motor Dimensions

X250, X252, X700, X2CE250, XCE252, XCE700, XCE702

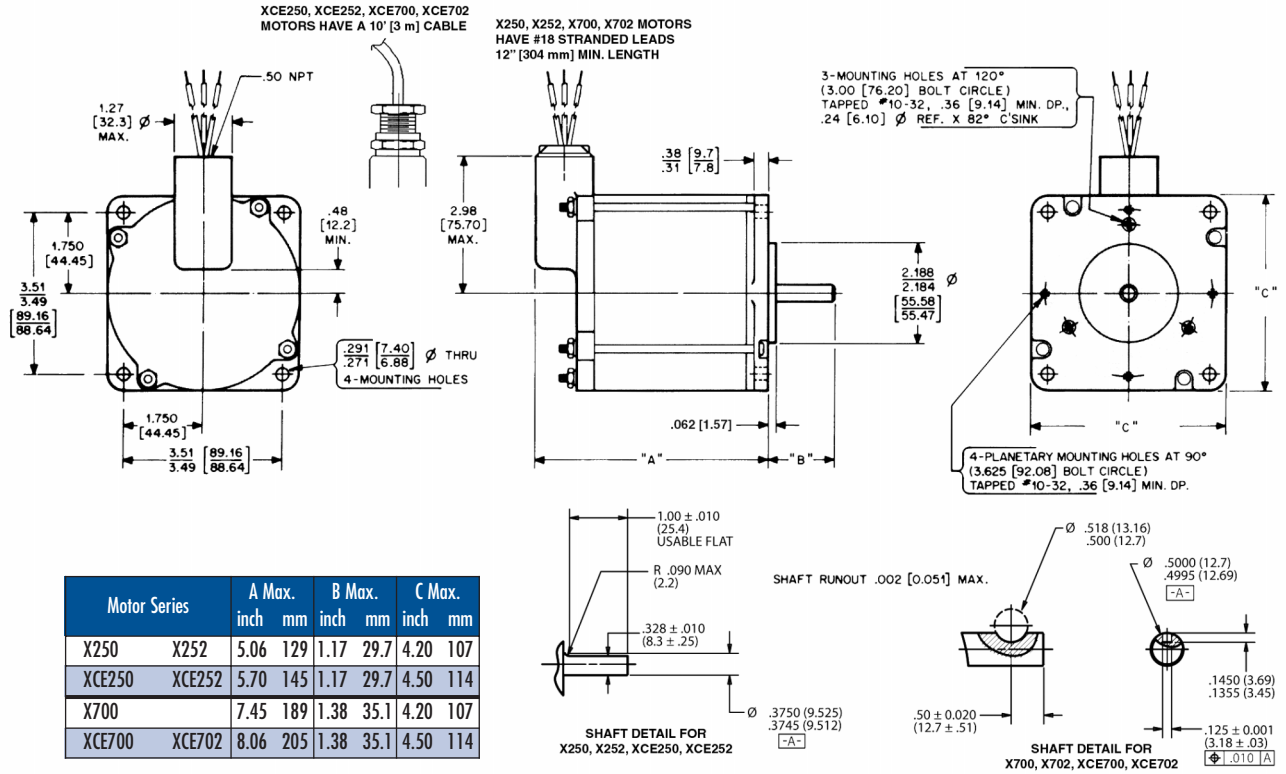

Dimensions are shown in inches (mm)

X1100, X1102, X1500, X1502, XCE1100, XCE1102, XCE1500, XCE1502

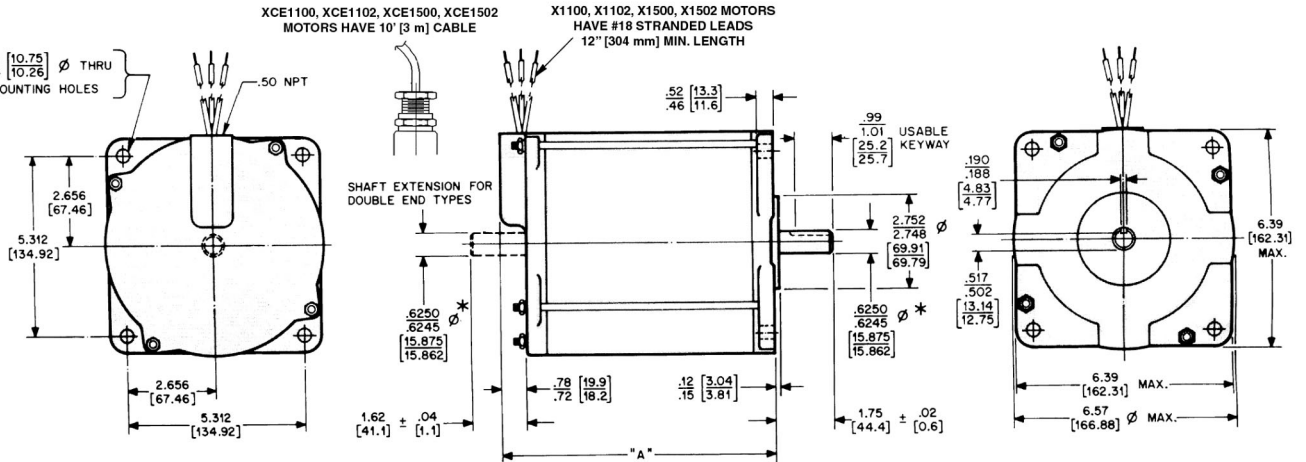

Dimensions are shown in inches (mm)

Phase Shifting Components

Capacitor Kits

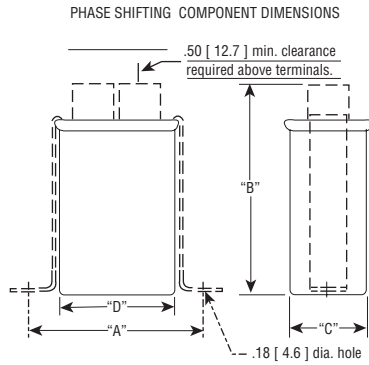

FIGURE C1

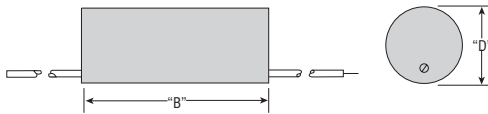
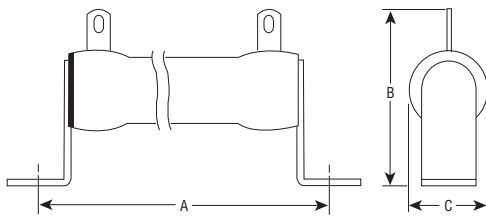

FIGURE C2

Kit Number	Figure	µfd	VAC	A		B		C		D	
				in	mm	in	mm	in	mm	in	mm
201053-010	C1	6.5	330	2.66	67.6	4.14	105	1.31	33	2.16	55
201053-012	C1	1.75	660	2.66	67.6	3.77	96	1.31	33	2.16	55
201053-014	C1	30	330	3.41	86.6	7.56	192	1.91	49	2.91	74
201053-016	C1	8	660	3.41	86.6	5.81	148	1.91	49	2.91	74
201053-019	C1	9	660	4.16	105.7	5.81	148	1.97	50	3.66	93
201053-026	C1	17.5	330	3.41	86.6	4.84	123	1.91	49	2.91	74
201053-028	C1	4	660	2.66	67.6	3.7	94	1.31	33	2.16	55
201053-029	C1	6	660	2.66	67.6	4.83	123	1.31	33	2.16	55
201053-030	C1	3	660	2.66	67.6	4.08	104	1.31	33	2.16	55
201053-032	C1	12.5	330	2.66	67.6	6.08	154	1.31	33	2.16	55
201053-037	C2	7.5	250	-	-	2.0	51	-	-	1.10	28
201053-038	C2	2	250	-	-	2.0	51	-	-	0.66	17
201053-041	C2	2.5	250	-	-	2.0	51	-	-	0.67	17
201053-042	C2	14	250	-	-	2.5	64	-	-	1.15	29
201053-044	C2	3	250	-	-	2.0	51	-	-	0.68	17
201053-061	C2	4	250	-	-	2.0	51	-	-	0.81	21
201053-063	C1	0.75	370	2.66	67.6	2.79	71	1.31	33	2.16	55
201053-068	C2	1.5	250	-	-	2.0	51	-	-	0.66	17
201053-069	C2	6	250	-	-	2.0	51	-	-	1.10	28
201053-070	C1	1	370	2.66	67.6	2.79	71	1.31	33	2.16	55
201053-071	C1	1.75	370	2.66	67.6	2.79	71	1.31	33	2.16	55
201053-072	C1	2	370	2.66	67.6	2.79	71	1.31	33	2.16	55
201053-073	C1	3	370	2.66	67.6	2.79	71	1.31	33	2.16	55
201053-074	C2	11	250	-	-	2.0	51	-	-	1.30	33
201053-075	C1	1.5	370	2.66	67.6	2.79	71	1.31	33	2.16	55
201053-076	C2	5	250	-	-	2.0	51	-	-	1.10	28
201053-081	C1	20	330	3.41	86.6	6.09	155	1.91	49	2.91	74
201053-082	C1	7.5	660	3.41	86.6	5.81	148	1.91	49	2.91	74

Resistor Kits



Kit Number	ohms	watts	A		B		C	
			in	mm	in	mm	in	mm
201052-013	150	50	4.88	124	1.44	37	1	25.4
201052-015	500	50	4.88	124	1.44	37	1	25.4
201052-018	250	200	11.5	292	2.75	70	1.13	28.7
201052-020	55	375	11.5	292	2.69	68.3	1.25	31.8
201052-025	100	160	9.38	238	2.5	64	1.13	28.7
201052-026	400	160	9.38	238	2.5	64	1.13	28.7
201052-027	150	100	5.88	150	2.76	70	1.38	35
201052-028	500	100	5.88	150	2.76	70	1.38	35
201052-033	1,000	12	2.5	64	0.94	24	0.32	8.1
* 201052-034	600	12	2.5	64	0.94	24	0.32	8.1
201052-035	600	25	3	76	1.94	50	0.75	19
* 201052-036	1,100	25	3	76	1.94	50	0.75	19
201052-037	300	50	4.88	124	1.44	37	1	25.4
* 201052-039	900	50	4.88	124	1.44	37	1	25.4
201052-041	250	50	4.88	124	1.44	37	1	25.4
* 201052-043	600	50	4.88	124	1.44	37	1	25.4
201052-045	1,000	100	5.88	150	2.76	70	1.38	35
* 201052-046	400	100	5.88	150	2.76	70	1.38	35
201052-047	600	100	5.88	150	2.76	70	1.38	35
201052-049	400	50	4.88	124	1.44	37	1	25.4
* 201052-050	1,000	25	3	76	1.94	50	0.75	19
201052-101	75	100	5.88	150	2.76	70	1.38	35
201052-102	200	100	5.88	150	2.76	70	1.38	35
201052-103	250	100	5.88	150	2.76	70	1.38	35
201052-104	50	200	11.5	292	2.75	70	1.13	28.7
201052-105	200	200	11.5	292	2.75	70	1.13	28.7
201052-106	150	200	11.5	292	2.75	70	1.13	28.7

* Kit contains two resistors. Dimensions shown are for one resistor.

Gearbox Kits & Gearmotors

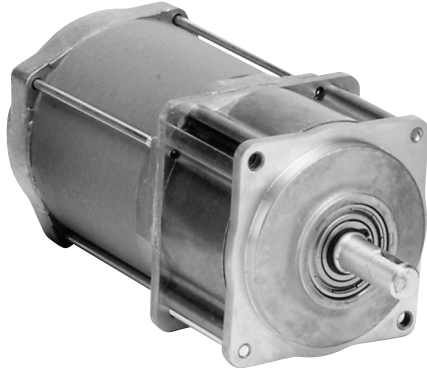

- Ratios from 3:1 to 125:1
- Up to 5,000 oz-in (3,530 Ncm) torque
- 150 lb (68 kg) radial load capacity
- 100 lb (45 kg) axial load capacity
- Typical output shaft backlash is 2 (degrees)
- Maintenance free
- Kits for field installation to NEMA 34 motors.

* Note: Gearboxes for KS093 motors must be installed at the factory.

Superior Electric gearmotors mate NEMA 34 synchronous motors with step-down gearboxes for applications where slow shaft speeds or high torque are needed.

The rugged gearbox developed for Superior gearmotors has been designed to allow high output torque ratings, while providing long life. The gearboxes are permanently lubricated and no scheduled maintenance is needed. Gearbox efficiency is 88% to 68% depending on the number of stages. The output shaft of the gear assembly is provided with a standard Woodruff key for easy and positive coupling to the load.

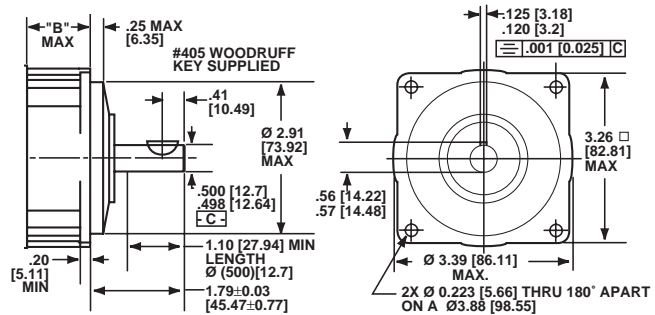

Gearbox Kits

Gearbox (G) Ratio	Kit PartNumber	"B" Body length		Typical Input Shaft Lost Motion	Typical Output Shaft Backlash	Reflected Moment of Inertia		Efficiency
		In	mm	Degrees	Degrees	Lb-In2	Kg-Cm2	
3:1	220763-003	1.19	30.2	6	2	0.105	0.307	88%
4:1	220763-004	1.19	30.2	7	2	0.035	0.102	88%
5:1	220763-005	1.19	30.2	8	2	0.021	0.061	88%
9:1	220763-009	1.81	46.0	43	2	0.115	0.336	77%
12:1	220763-012	1.81	46.0	61	2	0.041	0.120	77%
15:1	220763-015	1.81	46.0	81	2	0.024	0.070	77%
16:1	220763-016	1.81	46.0	58	2	0.037	0.108	77%
20:1	220763-020	1.81	46.0	65	2	0.023	0.067	77%
25:1	220763-025	1.81	46.0	73	2	0.022	0.064	77%
27:1	220763-027	2.38	60.5	109	2	0.114	0.334	68%
36:1	220763-036	2.38	60.5	110	2	0.041	0.120	68%
45:1	220763-045	2.38	60.5	112	2	0.024	0.070	68%
48:1	220763-048	2.38	60.5	113	2	0.037	0.108	68%
60:1	220763-060	2.38	60.5	115	2	0.023	0.067	68%
64:1	220763-064	2.38	60.5	116	2	0.037	0.108	68%
75:1	220763-075	2.38	60.5	118	2	0.022	0.064	68%
80:1	220763-080	2.38	60.5	119	2	0.023	0.067	68%
100:1	220763-100	2.38	60.5	124	2	0.022	0.064	68%
125:1	220763-125	2.38	60.5	130	2	0.022	0.064	68%

KS09 Gearmotor Ratings

See pages 6-9 for motor information

Gearmotor Model		Gear Ratio	Speed (RPM)		Torque (min)		Maximum Rigidly Attached Load Inertia			
			@ 60 Hz	@ 50 Hz	oz-in	N-cm	1 Phase, 60 Hz		1 Phase, 50 Hz	
120 Volt	240 Volt						lb-in ²	kg-cm ²	lb-in ²	kg-cm ²
KSL091T1YG3	KSL091T2YG3	3:1	24	20	634	447	31	90	35	102
KSL091T1YG4	KSL091T2YG4	4:1	18	15	845	597	56	163	63	184
KSL091T1YG5	KSL091T2YG5	5:1	14.4	12	1,056	746	88	256	99	288
KSL091T1YG9	KSL091T2YG9	9:1	8	6.667	1,663	1,175	242	709	273	800
KSL091T1YG12	KSL091T2YG12	12:1	6	5	2,218	1,566	439	1,284	494	1,447
KSL091T1YG15	KSL091T2YG15	15:1	4.8	4	2,772	1,958	689	2,016	775	2,269
KSL091T1YG16	KSL091T2YG16	16:1	4.5	3.75	2,957	2,088	781	2,286	880	2,574
KSL091T1YG20	KSL091T2YG20	20:1	3.6	3	3,696	2,610	1,225	3,584	1,379	4,035
KSL091T1YG25	KSL091T2YG25	25:1	2.88	2.4	4,620	3,263	1,914	5,602	2,155	6,306
KSL091T1YG27	KSL091T2YG27	27:1	2.667	2.222	4,406	3,112	1,926	5,637	2,174	6,362
KSL091T1YG36	KSL091T2YG36	36:1	2	1.667	5,000	3,530	3,489	10,209	3,930	11,498
KSL091T1YG45	KSL091T2YG45	45:1	1.6	1.333	5,000	3,530	5,475	16,020	6,163	18,034
KSL091T1YG48	KSL091T2YG48	48:1	1.5	1.25	5,000	3,530	6,209	18,167	6,992	20,459
KSL091T1YG60	KSL091T2YG60	60:1	1.2	1	5,000	3,530	9,736	28,487	10,960	32,068
KSL091T1YG64	KSL091T2YG64	64:1	1.125	0.9375	5,000	3,530	11,038	32,297	12,431	36,372
KSL091T1YG75	KSL091T2YG75	75:1	0.96	0.8	5,000	3,530	15,216	44,522	17,128	50,118
KSL091T1YG80	KSL091T2YG80	80:1	0.9	0.75	5,000	3,530	17,308	50,643	19,484	57,010
KSL091T1YG100	KSL091T2YG100	100:1	0.72	0.6	5,000	3,530	27,050	79,149	30,450	89,098
KSL091T1YG125	KSL091T2YG125	125:1	0.576	0.48	5,000	3,530	42,266	123,671	47,579	139,215
KSL092T1YG3	KSL092T2YG3	3:1	24	20	1,188	839	63	183	63	183
KSL092T1YG4	KSL092T2YG4	4:1	18	15	1,584	1,119	112	328	112	328
KSL092T1YG5	KSL092T2YG5	5:1	14.4	12	1,980	1,398	176	514	176	514
KSL092T1YG9	KSL092T2YG9	9:1	8	6.667	3,119	2,202	492	1,439	492	1,439
KSL092T1YG12	KSL092T2YG12	12:1	6	5	4,158	2,936	882	2,582	882	2,582
KSL092T1YG15	KSL092T2YG15	15:1	4.8	4	5,000	3,530	1,382	4,043	1,382	4,043
KSL092T1YG16	KSL092T2YG16	16:1	4.5	3.75	5,000	3,530	1,570	4,593	1,570	4,593
KSL092T1YG20	KSL092T2YG20	20:1	3.6	3	5,000	3,530	2,457	7,189	2,457	7,189
KSL092T1YG25	KSL092T2YG25	25:1	2.88	2.4	5,000	3,530	3,839	11,234	3,839	11,234
KSL092T1YG27	KSL092T2YG27	27:1	2.667	2.222	5,000	3,530	3,909	11,438	3,909	11,438
KSL093T1YG3	KSL093T2YG3	3:1	24	20	1,848	1,305	102	299	110	322
KSL093T1YG4	KSL093T2YG4	4:1	18	15	2,464	1,740	183	534	197	575
KSL093T1YG5	KSL093T2YG5	5:1	14.4	12	3,080	2,175	286	835	308	900
KSL093T1YG9	KSL093T2YG9	9:1	8	6.667	4,851	3,426	804	2,351	866	2,534
KSL093T1YG12	KSL093T2YG12	12:1	6	5	5,000	3,530	1,437	4,204	1,548	4,529

www.DanaherMotion.com • 704-588-5693

SS240, SS450 Gearmotor Ratings

See pages 10-13 for motor information

Gearmotor Model		Gear Ratio	Speed (RPM)		Torque (min)		Maximum Rigidly Attached Load Inertia					
			@ 60 Hz	@ 50 Hz	oz-in	N-cm	1 Phase, 60 Hz		1 Phase, 50 Hz		3 Phase	
120 Volt	240 Volt					lb-in2	kg-cm2	lb-in2	kg-cm2	lb-in2	kg-cm2	
SS241LG3	SS242LG3	3:1	24	20	634	447	19	56	7	21	19	56
SS241LG4	SS242LG4	4:1	18	15	845	597	35	102	14	40	35	102
SS241LG5	SS242LG5	5:1	14.4	12	1,056	746	55	160	22	63	55	160
SS241LG9	SS242LG9	9:1	8	6.667	1,663	1,175	149	435	55	162	149	435
SS241LG12	SS242LG12	12:1	6	5	2,218	1,566	273	798	106	311	273	798
SS241LG15	SS242LG15	15:1	4.8	4	2,772	1,958	429	1,255	169	495	429	1,255
SS241LG16	SS242LG16	16:1	4.5	3.75	2,957	2,088	486	1,421	190	555	486	1,421
SS241LG20	SS242LG20	20:1	3.6	3	3,696	2,610	763	2,232	301	880	763	2,232
SS241LG25	SS242LG25	25:1	2.88	2.4	4,620	3,263	1,193	3,489	471	1,377	1,193	3,489
SS241LG27	SS242LG27	27:1	2.667	2.222	4,406	3,112	1,183	3,461	439	1,285	1,183	3,461
SS241LG36	SS242LG36	36:1	2	1.667	5,000	3,530	2,167	6,341	845	2,473	2,167	6,341
SS241LG45	SS242LG45	45:1	1.6	1.333	5,000	3,530	3,409	9,976	1,344	3,932	3,409	9,976
SS241LG48	SS242LG48	48:1	1.5	1.25	5,000	3,530	3,859	11,291	1,509	4,415	3,859	11,291
SS241LG60	SS242LG60	60:1	1.2	1	5,000	3,530	6,064	17,742	2,392	6,998	6,064	17,742
SS241LG64	SS242LG64	64:1	1.125	0.9375	5,000	3,530	6,860	20,073	2,682	7,848	6,860	20,073
SS241LG75	SS242LG75	75:1	0.96	0.8	5,000	3,530	9,478	27,734	3,741	10,946	9,478	27,734
SS241LG80	SS242LG80	80:1	0.9	0.75	5,000	3,530	10,780	31,542	4,252	12,441	10,780	31,542
SS241LG100	SS242LG100	100:1	0.72	0.6	5,000	3,530	16,850	49,304	6,650	19,459	16,850	49,304
SS241LG125	SS242LG125	125:1	0.576	0.48	5,000	3,530	26,329	77,038	10,391	30,405	26,329	77,038
SS451LG3	SS452LG3	3:1	24	20	1,188	839	43	125	15	44	35	102
SS451LG4	SS452LG4	4:1	18	15	1,584	1,119	77	225	28	81	63	184
SS451LG5	SS452LG5	5:1	14.4	12	1,980	1,398	121	353	44	127	99	288
SS451LG9	SS452LG9	9:1	8	6.667	3,119	2,202	336	983	118	344	273	800
SS451LG12	SS452LG12	12:1	6	5	4,158	2,936	605	1,771	217	636	494	1,447
SS451LG15	SS452LG15	15:1	4.8	4	5,000	3,530	949	2,776	342	1,002	775	2,269
SS451LG16	SS452LG16	16:1	4.5	3.75	5,000	3,530	1,077	3,151	387	1,132	880	2,574
SS451LG20	SS452LG20	20:1	3.6	3	5,000	3,530	1,687	4,936	609	1,782	1,379	4,035
SS451LG25	SS452LG25	25:1	2.88	2.4	5,000	3,530	2,636	7,714	952	2,785	2,155	6,306
SS451LG27	SS452LG27	27:1	2.667	2.222	5,000	3,530	2,670	7,812	935	2,736	2,174	6,362

Application Assistance

Parallel Motor Operation

Two or more Superior motors may be operated simultaneously from the same power source, if the total current requirement does not exceed the current capability of the supply. However, due to the motor starting characteristics, mechanical synchronization of the motors is not practical. As described under Starting And Stopping Characteristics, one motor may achieve running speed within 5 milliseconds while a second motor, because of its at rest position, may require 25 milliseconds to achieve running speed.

Starting High Inertia Loads

The motor charts show the maximum load inertia that each motor model can start. Inertial loads as high as five to ten times these ratings can be started if a flexible coupling is used between the motor shaft and the load. The coupling should allow approximately 5° of shaft rotation before the full load is applied to the shaft. Rubber couplings are often used, as are chain drives with sufficient slack to allow the necessary shaft motion. Timing belts are also used, and in most cases will provide adequate flexing while providing smooth and quiet transmission of power.

Effects of Speed Reduction Gearing on Torque and Inertia

The combination of reduction gearing and a Superior motor provides increased torque as well as a lower operating speed. Output speed is decreased and torque increased by the factor of the gear ratio used minus losses due to gear train inefficiency. Gear losses are typically around 10% per mesh. Step-down gearing offers even greater gains in inertial load rating, since the inertia moving capability increases by the square of the gear ratio. Timing belts and pulleys can be used in place of gears for speed reduction and will provide the added benefit of a flexible coupling.

Coupling Motor to Load

Because of the extremely fast starting and stopping characteristics of a Superior AC synchronous motor, couplings, pulleys or other devices should be well secured to the motor shaft with the key provided, roll-pins, or set-screws.

If a coupling is to be press-fitted to the shaft, the motor must be held by the shaft (not by the gearbox or the motor case) when pressing the coupling in place. This will prevent damage to the motor bearings. The force used in pressing must not exceed the thrust force limit of the gearbox (100 pounds).

Switch Contact Protection

In some applications it may be desirable to protect the switch contacts from arcing and from transient voltages generated during switching. The most common method is the addition of resistors and capacitors across the switch contacts as shown in the diagram. Recommended values of the components are: resistor, 330 ohm, 1 watt; capacitor, 0.1 mfd, 250 Vac.

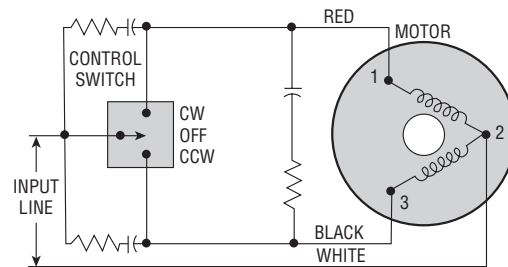

SWITCH PROTECTION NETWORK FOR AC OPERATION OF STANDARD MODELS

Temperature Considerations

The motors are rated for a maximum free-air ambient temperature of 40° C (104° F). However, it is possible to operate in higher ambient temperatures or above rated voltages if the motors are mounted on metal plates or are forced-air cooled. Do not exceed the maximum motor case temperature of 100° C (212° F).

Maximum Shaft Loads

Motor Series	Maximum Shaft Loads	
	Radial lb kg	Axial lb kg
KS06	15 6.8	25 11
KS09	25 11	50 23
KS09 Gearmotors	150 68	100 45
KS11	75 34	130 59
SS240, SS450	25 11	50 23
SS240, SS450 Gearmotors	150 68	100 45
X250, XCE250	25 11	50 23
X700, XCE700	25 11	50 23
X1100, XCE1100	50 23	100 45
X1500, XCE1500	50 23	100 45

Application Assistance (continued)

How to Select an AC Motor

To select a synchronous motor first determine the torque and moment of inertia characteristics of the load, as presented to the motor. The following examples show how to calculate these requirements in both standard U.S. and metric units.

Once the requirements of the application including input voltage and frequency are known, refer to the ratings shown on the motor charts and select the motor which best suits these requirements.

If additional information or technical assistance is needed, contact Superior Electric. A representative will be pleased to help you select the best motor for your application.

Gears and Pulleys

When the load is driven through gears or pulleys, the required motor torque is changed by the overall ratio.

For example, if the load is 90 ounce-inches (63.6 Ncm) and the step-down ratio is 3:1, the required torque would be 30 ounce-inches (21.2 Ncm).

Load inertia presented to the motor is changed by the square of the ratio. For example, with a load inertia of 4 pound-inches² (11.71 kg-cm²) and a 2:1 step-down ratio, the effective inertia would be 1 pound-inch² (2.93 kg-cm²) plus the inertia of the first gear or pulley.

Torque

Torque (oz-in) = Fr

Where F = Force (in ounces) required to drive the load
r = Radius (in inches)

Force can be measured using a pull type spring scale. The scale may be attached to a string that is wrapped around a pulley or a hand wheel attached to the scale. If the scale reading is in pounds, it must be converted into ounces to obtain a torque rating in ounce-inches.

For example: A 4" diameter pulley requires a 2 pound pull on the scale to rotate it.

$$F = 2 \text{ pounds} \times 16 = 32 \text{ ounces}$$

$$r = 4" \div 2 = 2"$$

$$\text{Torque} = 32 \times 2 = 64 \text{ oz-in}$$

Torque (Ncm) = Fr

Where F = Force (N) required to drive the load
r = radius (in cm)

Force can be measured using a pull type spring scale. If the scale reading is calibrated in kilograms, the scale reading must be multiplied by 9.8067 to obtain newtons. The scale should be attached to a string that is wrapped around a pulley or a hand wheel which is then attached to the load.

For example, a 10 cm diameter pulley requires a 1.5 newton (0.153 kg) pull on the scale to rotate it.

$$F = 1.5 \text{ newtons}$$

$$r = 5 \text{ cm}$$

$$\text{Torque} = 1.5 \times 5 = 7.5 \text{ Ncm}$$

Inertia

Moment of Inertia (lb-in²)

$$(\text{lb-in}^2) = \frac{Wr^2}{2} \text{ for a disk} \quad \text{or} \quad (\text{lb-in}^2) = \frac{W}{2} (r_1 - r_2) \text{ for a cylinder}$$

Where W = Weight in pounds
r = Radius in inches

For example: A load is a 8" diameter gear weighing 8 ounces

$$W = 8 \div 16 = .05 \text{ pounds}$$

$$r = 8" \div 2 = 4"$$

$$\text{Moment Of Inertia} = \frac{0.5 \times (4)^2}{2} = 4 \text{ lb-in}^2$$

Moment Of Inertia (kg-cm²)

$$J = \frac{Wr^2}{19.6134} \text{ for a disk} \quad \text{or} \quad J = \frac{W (r_1^2 - r_2^2)}{19.6134} \text{ for a cylinder}$$

Where W = newtons
r = cm

For example: A load is a 20 cm diameter gear weighing 0.25 newtons.

$$W = .25 \text{ newtons}$$

$$r = 10 \text{ cm}$$

$$\text{Moment Of Inertia} = \frac{0.25 \times 10^2}{19.6134} = 1.275 \text{ kg-cm}^2$$

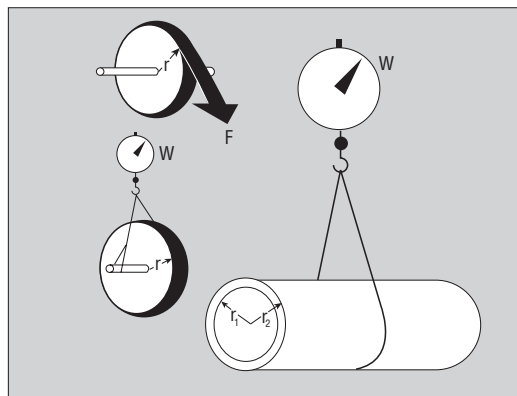

Conversion Factors

Length*

A \ B	mm	cm	m	inch	feet
mm	=====	0.1	0.001	0.03937	0.003281
cm	10	=====	0.01	0.3937	0.03281
m	1000	100	=====	39.37	3.281
inch	25.4	2.54	0.0254	=====	0.08333
feet	304.8	30.48	0.3048	12	=====

* Multiply units of "A" by indicated factor to obtain units of "B".

Force*

A \ B	g	kg	oz	lb	Newton
g	=====	0.001	0.03527	0.002205	0.0098
kg	1000	=====	35.27	2.205	9.807
oz	28.35	0.02835	=====	0.0625	0.278
lb	453.6	0.4536	16	=====	4.448
Newton	102	0.102	3.597	0.2248	=====

* Multiply units of "A" by indicated factor to obtain units of "B".

Inertia*

A \ B	kgm	kgcm	gcm	oz-in	oz-in-sec	lb-in	lb-in-sec	lb-ft	lb-ft-sec (slug ft)
kgm	=====	1.00×10^4	1.00×10^7	5.467×10^4	1.416×10^2	3.418×10^3	8.851	23.73	7.376×10^{-1}
kgcm	1.00×10^{-4}	=====	1.00×10^3	5.457	1.416×10^{-2}	3.418×10^{-1}	8.851×10^{-4}	2.373×10^{-3}	7.376×10^{-5}
gcm	1.00×10^{-7}	1.00×10^{-3}	=====	5.467×10^{-3}	1.416×10^{-5}	3.418×10^{-4}	8.851×10^{-7}	2.373×10^{-6}	7.376
oz-in	1.829×10^{-5}	1.829×10^{-1}	1.829×10^2	=====	2.590×10^{-3}	6.250×10^{-2}	1.619×10^{-4}	4.340×10^{-4}	1.349×10^{-5}
oz-in-sec	7.062×10^{-3}	70.61	7.062×10^4	3.861×10^2	=====	24.13	6.250×10^{-2}	1.676×10^{-1}	5.208×10^{-3}
lb-in	2.926×10^{-4}	2.926	2.926×10^3	1.600×10^{-1}	4.144×10^{-2}	=====	2.590×10^{-3}	6.944×10^{-3}	2.158×10^{-4}
lb-in-sec	1.130×10^{-1}	1.130×10^3	1.130×10^6	6.177×10^3	16	3.861×10^2	=====	2.681	8.333×10^{-2}
lb-ft	4.214×10^{-2}	4.214×10^2	4.214×10^5	2.304×10^3	5.968	1.440×10^2	3.730×10^{-1}	=====	3.180×10^{-2}
lb-ft-sec (slug ft)	1.356	1.356×10^4	1.356×10^7	7.413×10^4	1.920×10^2	4.633×10^5	12	32.17	=====

* Multiply units of "A" by indicated factor to obtain units of "B".

Torque*

A \ B	Nm	Ncm	dyn cm	kgm*	kgcm*	gcm*	oz-in	lb-ft	lb-in
Nm	=====	1.00×10^2	1.000×10^7	1.020×10^{-1}	10.20	1.020×10^4	1.416×10^2	7.376×10^{-1}	8.851
Ncm	1.000×10^{-2}	=====	1.000×10^5	1.020×10^{-3}	1.020×10^{-1}	1.020×10^2	1.416	7.376×10^{-3}	8.851×10^{-2}
dyn cm	1.000×10^{-7}	1.000×10^{-5}	=====	1.020×10^{-8}	1.020×10^{-6}	1.020×10^{-3}	1.416×10^{-5}	7.376×10^{-8}	8.851×10^{-7}
kgm**	9.807	9.807×10^2	9.807×10^7	=====	1.000×10^2	1.000×10^5	1.389×10^3	7.233	86.80
kgcm**	9.807×10^{-2}	9.807	9.807×10^5	1.000×10^{-2}	=====	1.000×10^3	13.89	7.233×10^{-2}	8.680×10^{-1}
gcm**	9.807×10^{-5}	9.807×10^{-3}	9.807×10^2	1.000×10^{-5}	1.000×10^{-3}	=====	1.389×10^{-2}	7.233×10^{-5}	8.680×10^{-4}
oz-in	7.062×10^{-3}	7.062×10^{-1}	7.062×10^4	7.201×10^{-4}	7.201×10^{-2}	72.01	=====	5.283×10^{-3}	6.250×10^{-2}
lb-ft	1.356	1.356×10^2	1.356×10^7	1.383×10^{-1}	13.83	1.383×10^4	1.920×10^2	=====	12
lb-in	1.130×10^{-1}	11.30	1.130×10^6	1.152×10^{-2}	1.152	1.152×10^3	16	8.330×10^{-2}	=====

* Multiply units of "A" by indicated factor to obtain units of "B".

** Sometimes written as kpm, kpcm, and pcm, respectively, to denote the force equivalent of the kg and g mass.

Distribution Coast-To-Coast and International

The Superior Electric brand is a global leader in the engineering, manufacturing, and marketing of precision motion and control products for industrial applications. All Superior motors and controls are backed by highly specialized engineers and service people who can help solve your production challenges. Superior Electric's capabilities and products have improved operations for companies around the world.

Through Danaher Motion's extensive authorized distributor network, Superior Electric products are available worldwide. These distributors provide convenient services by offering technical support, replacement parts, and literature, as well as an extensive inventory of models off-the-shelf for the fastest possible delivery.

Call Superior Electric customer service for ordering and application information or for the address of the nearest authorized distributor for Superior Electric products.

MC Supply Co., Inc
1200 Woodruff Rd
Suite H1
GREENVILLE SC 29607
www.MCSupplyCo.com

**Superior
Electric**

13500-J South Point Blvd. • Charlotte, NC 28273 U.S.A.
TEL: 704-588-5693 • FAX: 704-588-5695

Danaher Motion Customer Support Center

13500-J South Point Blvd.
Charlotte, NC 28273
Tel: 704-588-5693
Fax: 704-588-5695
Support email: sales2@DanaherMotion.com
Web: www.DanaherMotion.com

In Europe

Danaher Motion GmbH & Co. KG
Robert-Bosch-Straße 10
64331 Weiterstadt, Germany
Tel: +49 (0) 6151-8796-10
Fax: +49 (0) 6151-8796-123
Internet: www.DanaherMotion.de



www.DanaherMotion.com